



Pro-MEC  
**Vacuum Circuit Breakers**  
**Vacuum Interrupter**



## Vacuum Circuit Breaker & Vacuum Interrupter



7.2kV Draw-out (F class)

LSIS Pro-MEC VCB is user-friendly to give more convenience and safety by providing high speed interrupting time (3cycles), adopting the rapid auto-reclosing method, and having wide range of accessories.



24kV Draw-out (F class)

# Pro-MEC VCB/VI

Contents :

# H1

## Vacuum Circuit Breaker

Ratings	H1-4
Constructional and operating characteristics	H1-8
Control circuit diagram	H1-9
7.2kV dimension	H1-10
12kV dimension	H1-19
17.5kV dimension	H1-24
24kV dimension	H1-27
Accessories	H1-35
Types and ordering information	H1-40

## Vacuum Interrupter

Features & Ordering information	H1-43
VI internal structure	H1-44
Basic functions and interrupting action	H1-45
VI endurance by interrupting current	H1-46
Dimensions	H1-48
Technical data	H1-50



# Vacuum Circuit Breaker

LSIS Pro-MEC VCB is user-friendly to give more convenience and safety by providing high speed interrupting time (3cycles), adopting the rapid auto-reclosing method, and having wide range of accessories.



**7.2kV Draw-out (F class)**



**24kV Draw-out (F class)**

## Wide range of accessories (optional)



- Key Lock
- Padlock of earthing switch
- Button padlock
- Position switch of the earthing switch
- Button cover
- Locking coil of earthing switch
- Position switch (Cell switch)
- Shutter padlock
- Preparatory trip coil (Secondary trip coil)
- MOC (Mechanically operated cell switch)
- Latch checking switch
- TOC (Truck operated cell switch)
- Charge indicator
- Code plate (Miss insertion prevention)
- Position padlock
- Capacitor trip device
- Earthing switch Note 1)
- Rectifier

Note 1) The earthing switch is not available for 17.5kV VCB.

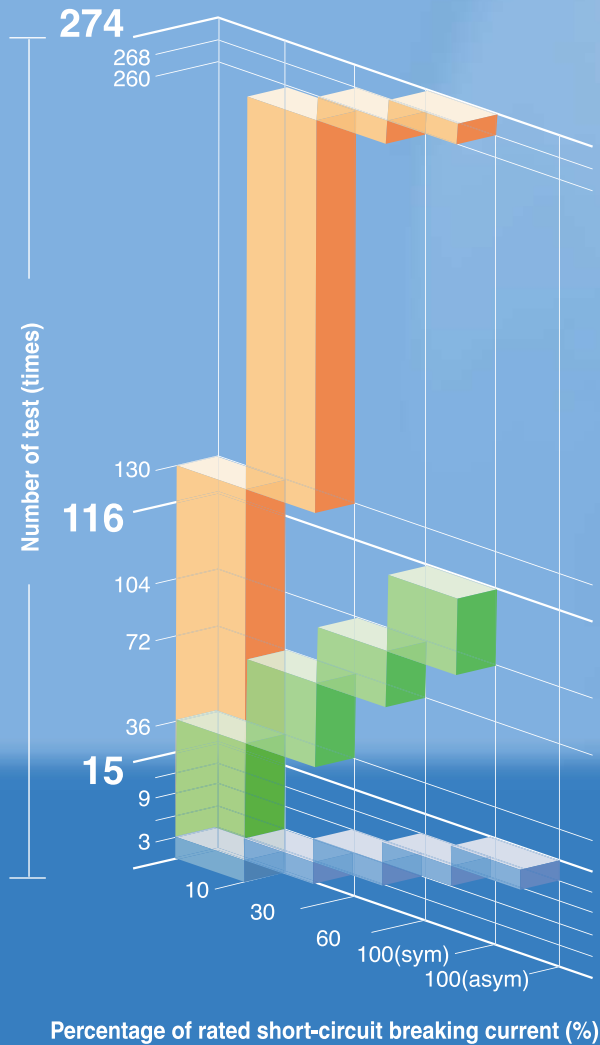
# [ Comparison table for VCB (Short circuit test) ]



Comparison table for VCB (Short circuit test)

-  IEC 62271-100 E2[List 1] **PROF MEC**
-  IEC 62271-100 E2[List 2]
-  IEC 60056 / 62271-100 E1  
  - E1
  - List 1 is preferred.
  - List 2 may be used as an alternative for circuit-breakers used for solidly earthed systems.

## High reliability of the operating mechanism

- Separate design of the main circuit from the operating mechanism.
- Adopt the toggle link method.
- Improved the reliability of electric circuit.
- Adopt the rapid auto-reclosing method as a standard option. (O-0.3sec.-CO-3min.-CO)

## High interrupting performance

- Make short of the interrupting time. (3cycles)
- Increase the rated short-circuit withstand characteristics. (1sec. to 3sec.)

## Great operational safety

- Reinforce the insulation in the conduct, by adopting the molded housing in each phase.
- Built in the device making the contacts open first when draw in and out.
- Adopt the tulip-shape connection between the cradle and the VCB.

# Vacuum Circuit Breaker

## Ratings

Type		LVB-06□-32D			LVB-06□-40D				
Rated voltage	(kV)	7.2			7.2				
Rated normal current	(A)	1250	2000	3150	1250	2000	3150		
Rated frequency	(Hz)	50/60			50/60				
Rated short-circuit breaking current	(kA)	31.5			40				
Rated short-circuit breaking capacity	(MVA)	390			500				
Rated short-time withstand current	(kA/3sec)	31.5			40				
Rated short-circuit making current	(kAp)	82			104				
Rated breaking time	(Cycle)	3			3				
Rated opening time	(sec)	≤ 0.04			≤ 0.04				
No-load closing time	(sec)	≤ 0.06			≤ 0.06				
Withstand voltage	Power frequency (kV/min)	20			20				
	Impulse (kV/1.2 × 50 $\mu$ s)	60			60				
Rated operating sequence		O-0.3s-CO-3min-CO			O-0.3s-CO-3min-CO				
Type test	Mechanical	M2 (10,000 times)			M2 (10,000 times)				
	Electrical	E2 (List1)			E2 (List1)				
	Capacitive current switching <i>Note 1)</i>	C2			C2				
Lifetime	Mechanical	Without maintenance (Time)	20000			20000			
		Maintenance (Time)	30000			30000			
	Electrical	Without maintenance (Time)	20000			20000			
		Maintenance (Time)	30000			30000			
Auxiliary switch		4a4b, 10a10b			4a4b, 10a10b				
Installing method	Fixed		Visible, Fixed		Visible, Fixed		Visible, Fixed		
	Draw-out type	E-type	Visible, Tulip		Visible, Clip		Visible, Tulip		
		F-type	Visible, Tulip		Visible, Tulip		Visible, Tulip		
		G-type <i>Note 2)</i>	-	Visible, Tulip		Visible, Tulip		Visible, Tulip	
			T	Enclosed, Tulip		-		Enclosed, Tulip	
M-type	Enclosed, Tulip -		-		Enclosed, Tulip				
Weight <i>Note 3)</i>	VCB	E-type (kg)	131.5	134.5	210	135	138	210	
		F-type (kg)	132.5	135.5	211	136	139	211	
		G, M-type (kg)	132.5(159)	135.5(160)	220	136(162.5)	139(163.5)	220	
	Cradle	E-type (kg)	52	60	131	52	60	131	
		F-type (kg)	54.5	62.5	135	54.5	62.5	135	
		G-type (kg)	62.5(110)	135(117)	155	62.5(110)	135(117)	155	
Applied standard		IEC 62271-100			IEC 62271-100				
Test laboratory	KERI <i>Note 4)</i>	■			■				

*Note 1)* Applied cable-charging current switching test

*2)* In the event of ordering Enclosed Tulip type for G class VCB, please add "T" in the end of type name. (Ex: LVB-06G-20D/06-1A2B-T)

*3)* ( ) indicates the weight of Enclosed Tulip installing method VCB.

*4)* KERI: Korea Electrotechnology Research Institute



▲ Enclosed VCB  
(Draw-out type, G-type)



▲ G-type Cradle  
(Enclosed, Tulip contact)



▲ Visible, Clip contact



▲ Visible, Tulip contact



▲ Enclosed, Tulip contact

Type		LVB-12□-32D/12, 20-T, 30			LVB-12□-40D/12, 20, 30			LVB-17□-40D/12, 20, 30			
Rated voltage	(kV)	12			12			17.5			
Rated normal current	(A)	1250	2000	3150	1250	2000	3150	1250	2000	3150	
Rated frequency	(Hz)	60(E1,E2,C2: PT & T)			50(E1,C2:KEMA), 60(M2,E2,C2: PT & T)			60			
Rated short-circuit breaking current	(kA)	31.5			40			40			
Rated short-circuit breaking capacity	(MVA)	650			831			1200			
Rated short-time withstand current	(kA/3sec)	31.5			40			40			
Rated short-circuit making current	(kAp)	81.9			104			104			
Rated breaking time	(Cycle)	3			3			3			
Rated opening time	(sec)	0.04			0.04			≤0.04			
No-load closing time	(sec)	0.06			0.06			≤0.06			
Withstand voltage	Power frequency (kV/min)	28			28			38			
	Impulse (kV/1.2 × 50 μs)	75			75			95			
Rated operating sequence		O-0.3s-CO-3min-CO			O-0.3s-CO-3min-CO			O-0.3s-CO-3min-CO			
Type test	Mechanical	M2 (10,000 times)			M2 (10,000 times)			M2 (10,000 times)			
	Electrical	E2 (List 1)			E2 (List 1)			E2 (List 1)			
	Capacitive current switching <b>Note)</b>	C2			C2			C2			
Lifetime	Mechanical	Without maintenance (Time)	20,000			20,000			20,000		
		Maintenance (Time)	30,000			30,000			30,000		
	Electrical	Without maintenance (Time)	20,000			20,000			20,000		
		Maintenance (Time)	30,000			30,000			30,000		
Auxiliary switch		4a4b, 10a10b			4a4b, 10a10b			4a4b, 10a10b			
Installing Method	Fixed	-			-			-			
	Draw-out type	E-TYPE	-			-			-		
		F-TYPE	-			-			-		
		G-TYPE	Enclosed, Tulip	Visible, Tulip		Enclosed, Tulip	Visible, Tulip		Visible, Tulip		
	M-TYPE	Enclosed, Tulip	-		-		-				
Weight	VCB	E-TYPE (kg)	-			-			-		
		F-TYPE (kg)	-			-			-		
		G, M-TYPE (kg)	159	160	220	162	163	220	200	205	260
	Cradle	E-TYPE (kg)	-	-	-	-	-	-	-	-	-
		F-TYPE (kg)	-	-	-	-	-	-	-	-	-
		G, M-TYPE (kg)	110	117	155	110	117	155	175	175	200
Applied standard		IEC 62271-100									
Test laboratory		PT & T: E1, E2, C2, M2						KEMA, PT & T			

Note) Applied cable-charging current switching test

# Vacuum Circuit Breaker

## Ratings

Type		LVB-20□-13D	LVB-20□-13D/T	LVB-20□-16D	LVB-20□-16D/T	LVB-20□-25D	LVB-20□-25D/T	
Rated voltage	(kV)	24		24		24		
Rated normal current	(A)	630		630		630		
		1250		1250		1250		
		2000						
Rated frequency	(Hz)	50/60		50/60		50/60		
Rated short-circuit breaking current	(kA)	12.5		16		25		
Rated short-circuit breaking capacity	(MVA)	520		665		1000		
Rated short-time withstand current	(kA/3sec)	12.5		16		25		
Rated short-circuit making current	(kAp)	32.5		40		65		
Rated breaking time	(Cycle)	3		3		3		
Rated opening time	(sec)	≤ 0.04		≤ 0.04		≤ 0.04		
No-load closing time	(sec)	≤ 0.06		≤ 0.06		≤ 0.06		
Withstand voltage	Power frequency (kV/min)	50		50		50		
	Impulse (kV/1.2 × 50 μs)	125		125		125		
Rated operating sequence		O-0.3s-CO-3min-CO		O-0.3s-CO-3min-CO		O-0.3s-CO-3min-CO		
Type test	Mechanical	M2(10,000 times)		M2(10,000 times)		M2(10,000 times)		
	Electrical	E2 (List1)		E2 (List1)		E2 (List1)		
	Capacitive current switching <small>Note 1)</small>	C2		C2		C2		
Lifetime	Mechanical	Without maintenance (Time)	20000		20000		20000	
		Maintenance (Time)	30000		30000		30000	
	Electrical	Without maintenance (Time)	20000		20000		20000	
		Maintenance (Time)	30000		30000		30000	
Auxiliary switch		4a4b, 10a10b		4a4b, 10a10b		4a4b, 10a10b		
Installing method	Fixed	Visible, Fixed	-	Visible, Fixed	-	Visible, Fixed	-	
	Draw-out type	E-type	Visible, Clip	Enclosed, Tulip	Visible, Clip	Enclosed, Tulip	Visible, Clip	Enclosed, Tulip
		F-type	Visible, Clip	Enclosed, Tulip	Visible, Clip	Enclosed, Tulip	Visible, Clip	Enclosed, Tulip
		G-type <small>Note 2)</small>	Visible, Tulip	Enclosed, Tulip	Visible, Tulip	Enclosed, Tulip	Visible, Tulip	Enclosed, Tulip
M-type	-	Enclosed, Tulip	-	Enclosed, Tulip	-	Enclosed, Tulip		
Weight	VCB	E-type (kg)	145	145	145	145	145	
		F-type (kg)	145	145	145	145	145	
		G, M-type (kg)	155	187	155	187	155	187/218 (2000A)
	Cradle	E-type (kg)	80	80	80	80	80	80
		F-type (kg)	82	82	82	82	82	82
		G-type (kg)	110	120	110	120	110	120
Applied standard		IEC 62271-100		IEC 62271-100		IEC 62271-100		
Test laboratory	KERI	■		-		■		
	KEMA	-		■		■		

Note 1) Applied cable-charging breaking current

2) In the event of ordering Enclosed Tulip type for G class VCB, please add "T" in the end of type name. (Ex: LVB-06G-20D/06-1A2B-T)



▲ Fixed type VCB



▲ E-type cradle



▲ F-type cradle



▲ G-type cradle  
(Withdrawable by lever)



▲ G-type cradle  
(Withdrawable by screw)



## Motor

When the closing spring is charged, the control power of motor is turned off by the built-in limit s/w.

Rated voltage	The peak value of the inrush current (A)	Rated current (A)	Consumption power (W)	Charging time (Sec.)
DC 48V	21	4	350	13
DC 110V	20	3	330	12
DC 125V	20	3	330	12
DC 220V	17	2.6	374	12

Note 1) Range of the normal operating voltage: 85~110%  
2) DC 24V is the underdeveloped rating.

## Closing Coil (C)

The coil operated only when the power is applied continuously over 45ms. It has built-in electrically anti-pumping circuit.

Rated voltage	Rated current (A)
DC 48V	6
DC 110V	3
DC 125V	3
DC 220V	2.5

Note 1) Range of the normal operating voltage: 85~110%  
2) DC 24V is the underdeveloped rating.

## Shunt coil (TC)

When the VCB is 'ON' position, even though the control power of a shunt coil is 'OFF', the VCB maintains the 'ON' position.

Rated voltage	Rated current (A)
DC 48V	6
DC 110V	3
DC 125V	3
DC 220V	2.5

Note 1) Range of the normal operating voltage: 70~110%  
2) DC 24V is the underdeveloped rating.

## Auxiliary switch

Standard 4a4b / Optional 10a10b

Classification		General load (A)	Inductive load (A)	Contact configuration
Contact Ratings	AC	250V 10	5	4a4b 10a10b
		125V 10	5	
	DC 125V	250V	10	
			10	
		30V 10	5	

Note) The contact capacity of the following accessories are the same with that of the Aux. switch. Position switch, Closing spring contact, Charging complete indicating contact, Position switch of the earthing switch, Mechanically operated cell switch, Truck operated cell switch.

### • Position of the Aux.contact switch

VCB	"a" contact	"b" contact
ON	ON	OFF
OFF	OFF	ON

## Charge indicator of the closing spring

Indicating the condition of the closing spring.



## Position indicator of the main contacts

Indicating the 'Close' or the 'Open' of the main contacts.

Close position: 「ON」 Open position: 「OFF」



## Counter

Mechanically counts the switching of the VCB by 5digits analog type counter (Standard option)

# Vacuum Circuit Breaker

## Constructional and operating characteristics

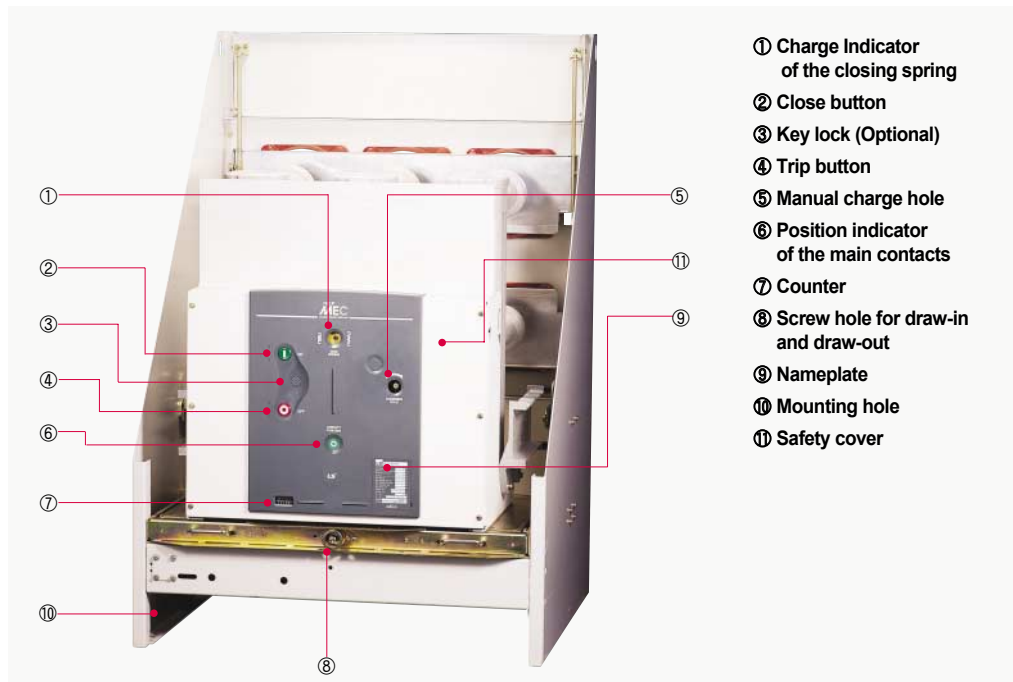

### Manual charge

Insert the charge handle into the manual charge hole in the front of a VCB, and rotate it to clockwise over 40times and the charge complete with a metal sound.

### Motor charge

If you apply the control power to a VCB, the closing spring will be charged automatically by a motor and then the control power will be turned off by the built-in limit s/w. Please use the same control voltage for motor, Closing coil, Trip coil.



### Sequence of the switching mechanism

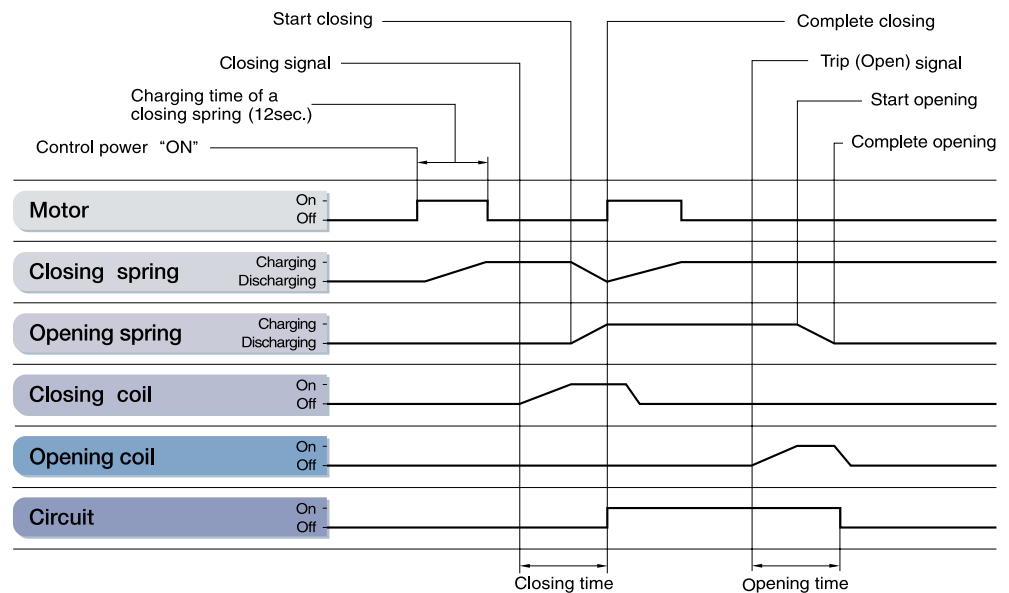

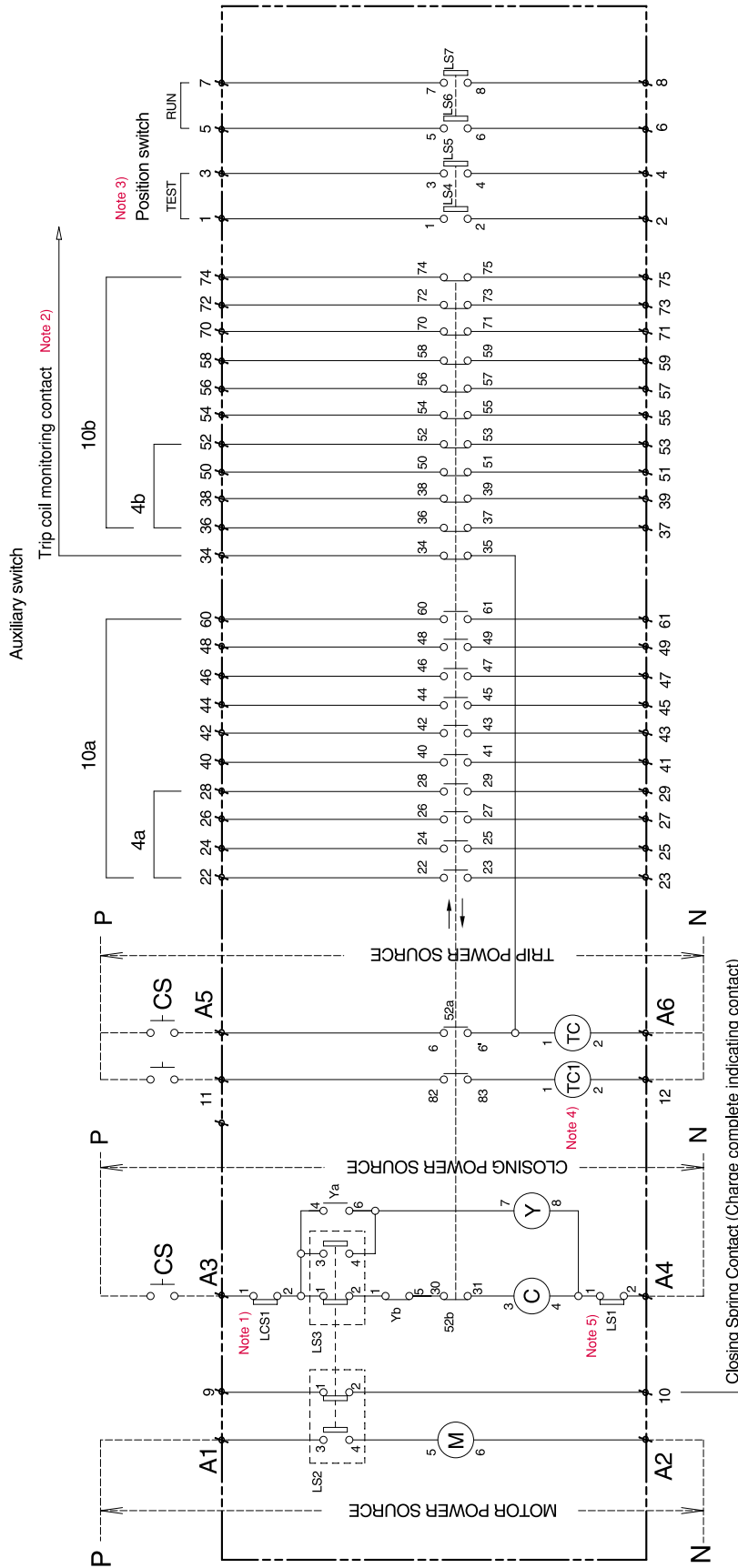

## Connecting terminal arrangement

A Type



(4a4b)

B Type

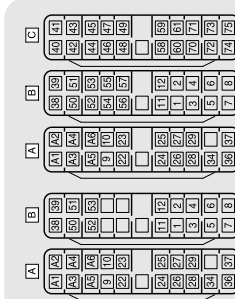

(10a10b)

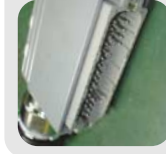

	16	15	14	13	12	11	10	9	8	7	6	5	4	3	2	1
A	25	28	27	26	25	24	23	22	21	A6	A5	A4	A3	A2	A1	
B	39	38	37	36	34											
C	53	52	51	50												
D	12	11	10	9												

(4a4b)

	16	15	14	13	12	11	10	9	8	7	6	5	4	3	2	1
A	41	40	28	27	26	25	24	23	22	A6	A5	A4	A3	A2	A1	
B	39	38	37	36	34											
C	75	74	73	72	71	70	59	58	57	56	55	54	53	52	51	50
D	12	11	10	9												

(10a10b)

- ∅ : External terminal of VCB
- 52: Auxiliary switch (NC)
- 52: Closing interlock limit switch (only withdrawable type)
- M: Spring charging motor
- LS1: Motor stopping, closing spring charged indication
- LS2: Anti-closing, anti-pumping limit switch
- LS3: Opening latch checking switch (preventing closing unless the trip latch is properly reset)
- LS4, LS5: Position s/w (close in test position)
- LS6, LS7: Position s/w (close in run position)
- TC: Trip coil
- TC1: Secondary trip coil
- C: Closing coil
- Y: Anti-pump relay
- 52a: Auxiliary switch (NO)

- Note 1) LCS1: Latch checking switch
- 2) Trip coil supervision (Trip coil monitoring contact)
- 3) Position switch: 4a (Terminal No.: 1, 2, 3, 4, 5, 6, 7, 8)
- 4) TC1: Secondary trip coil (Preparatory trip coil Terminal No.: 82,83)
- 5) In fixed type VCB, LS1 (Closing-coil limit switch) is not available.
- \* Above circuit diagram is based on 'OFF' status of VCB, and closing spring is charged.

# Vacuum Circuit Breaker

## 7.2kV dimension (VCB)

### LVB-06P-32D, 40D (Visible, Fixed) - (1250/2000A)

(Unit: mm)

• Top

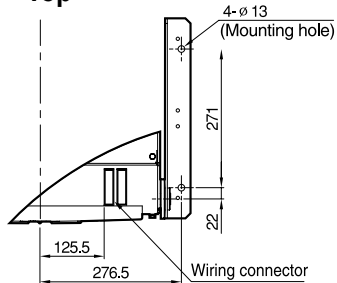

\*125.5 applied to all 7.2kV VCB.

<Terminal conductor>

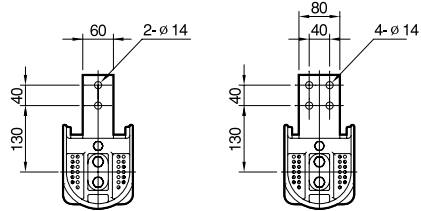

31.5/40kA 1250A

31.5/40kA 2000A

• Front

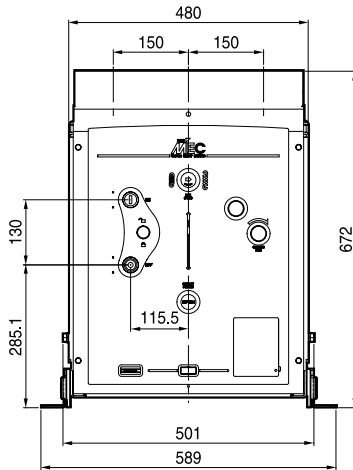

• Side

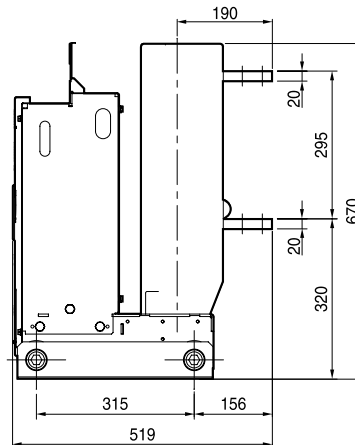

31.5/40kA 1250/2000A

### LVB-06P-32D, 40D (Visible, Fixed) - (3150A)

• Front

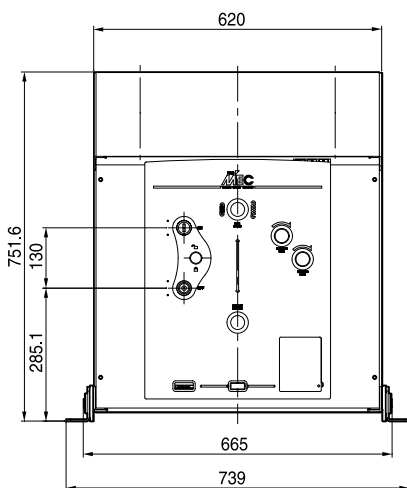

31.5/40kA 3150A

• Side

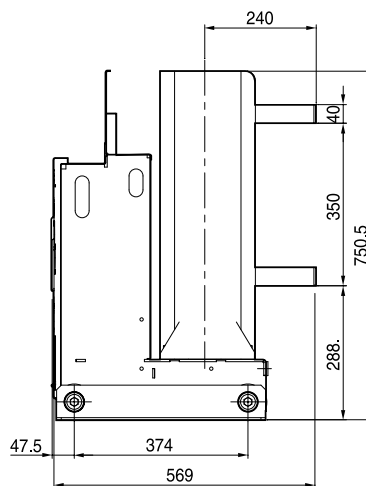

• Top

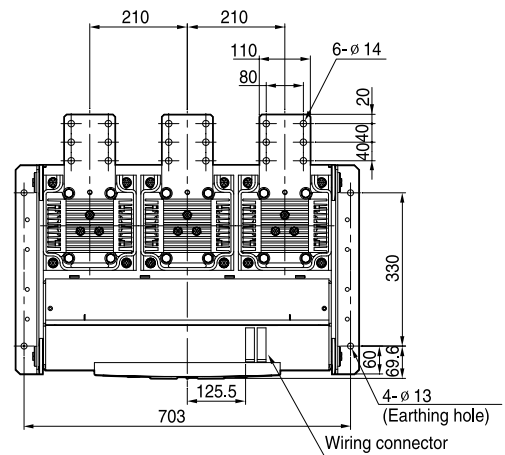

## LVB-06E, F, G-32D, 40D E, F, G class - (1250/2000A)

(Unit: mm)

### • Top

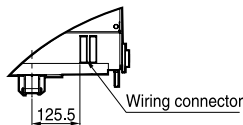

### <Terminal conductor>

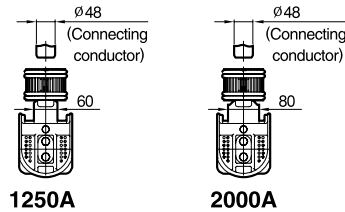

### • Front

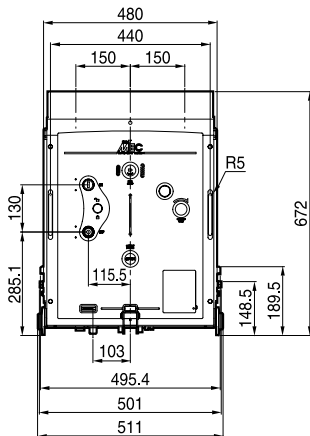

### • Side

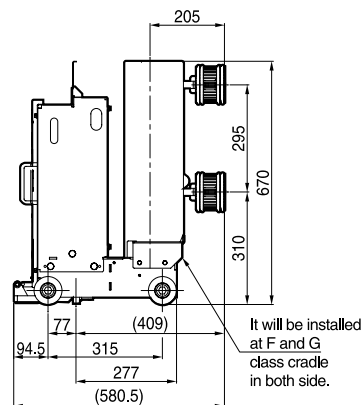

31.5/40kA 1250/2000A E, F, G class  
(Enclosed, Tulip contact)

## LVB-06G- 32D/T, 40D/T G class (Enclosed, Tulip contact) - (1250/2000A)

### • Front

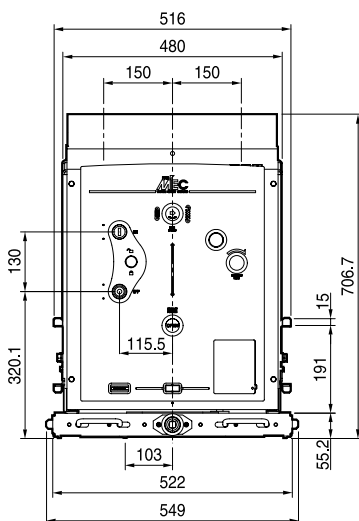

### • Side

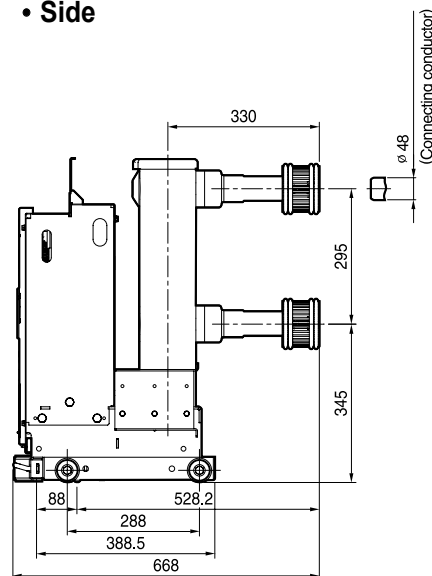

31.5/40kA 1250/2000A G class

# Vacuum Circuit Breaker

## 7.2kV dimension (VCB)

### LVB-06E-32D, 40D E class (Visible, Tulip contact) - (3150A)

(Unit: mm)

• Front

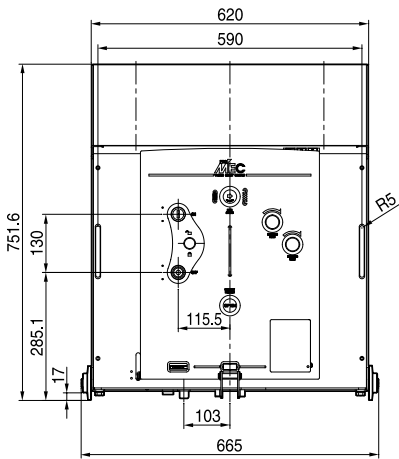

• Side

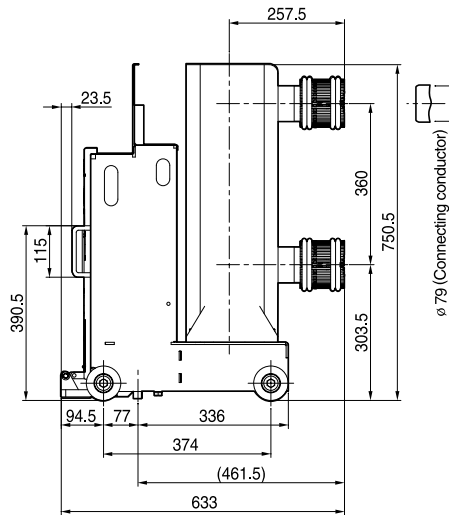

• Top

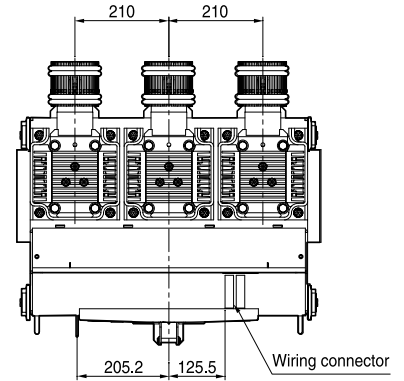

31.5/40kA 3150A E class

### LVB-06F-32D, 40D F class (Visible, Tulip contact) - (3150A)

• Front

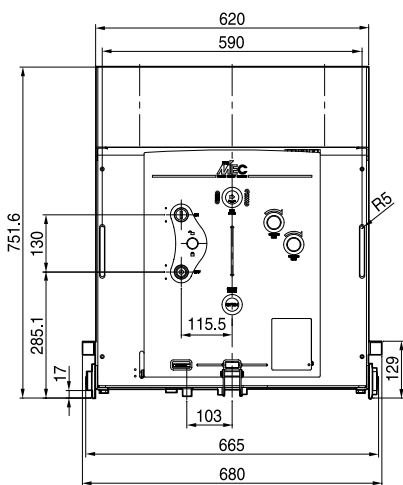

• Side

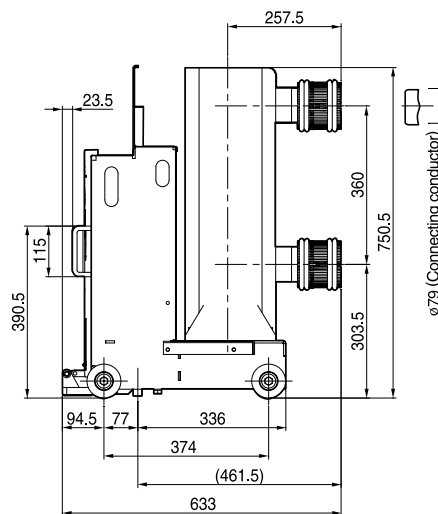

• Top

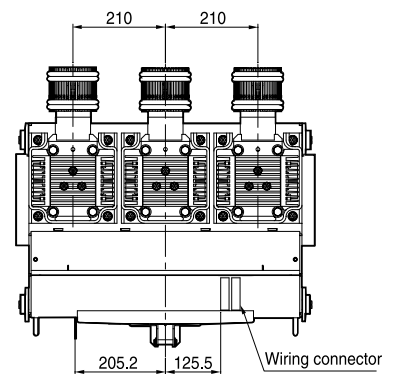

31.5/40kA 3150A F class

# LVB-06G-32D, 40D G class (Visible, Tulip contact) - (3150A)

(Unit: mm)

• Front

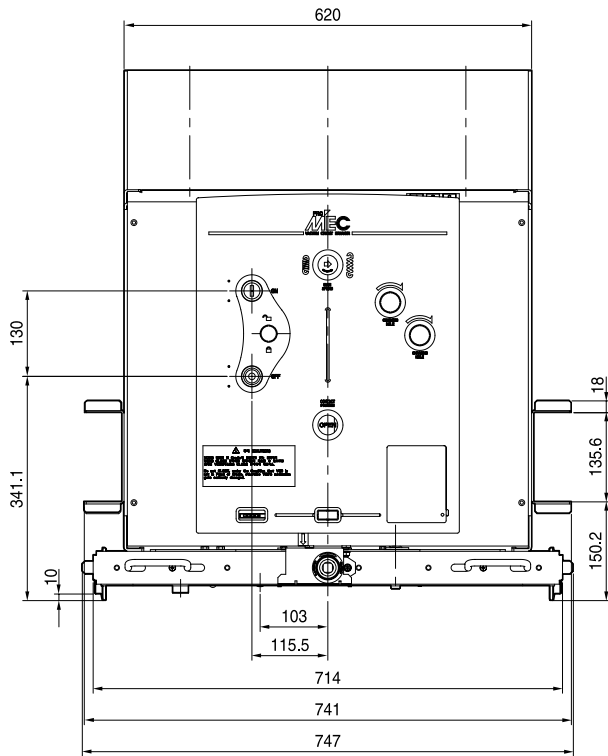

• Side

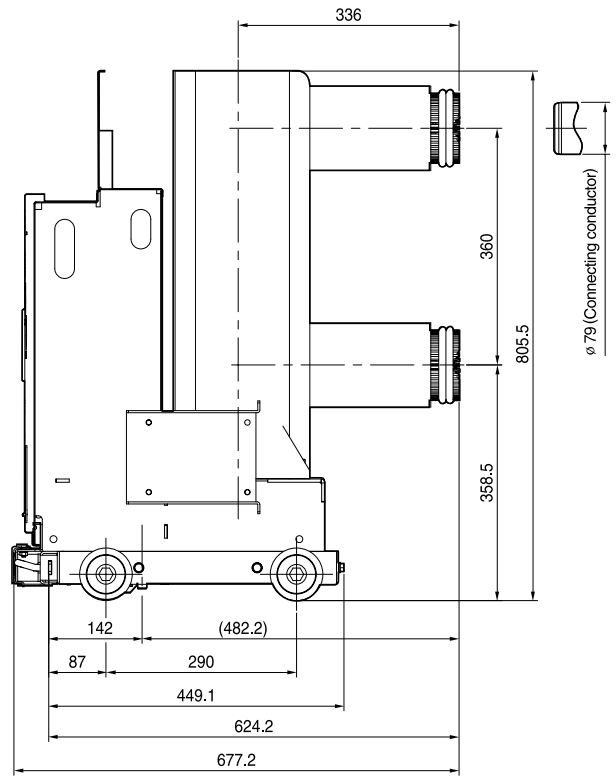

• Top

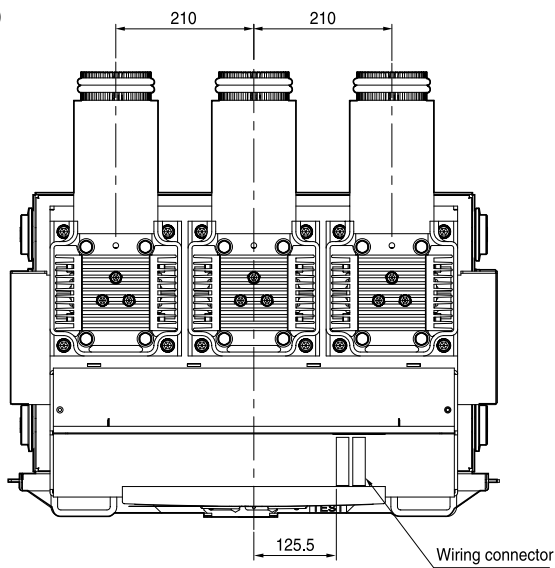

31.5/40kA 3150A G class

# Vacuum Circuit Breaker

## 7.2kV dimension (Cradle)

### LCL-06E-32D, 40D E class (Visible, Tulip contact)

(Unit: mm)

#### • Front

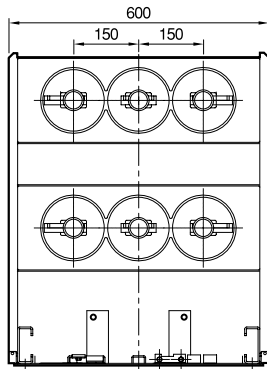

#### • Side

Rating	1250A	2000A
A	10	20

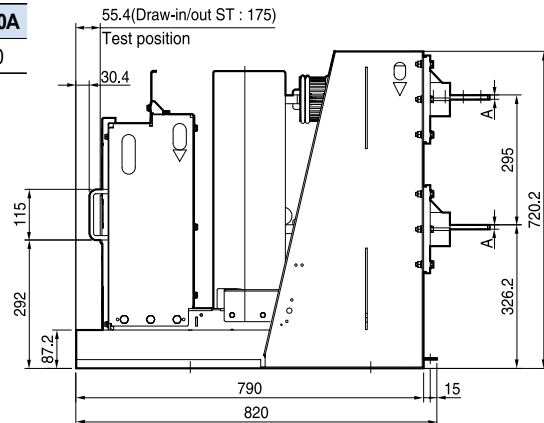

31.5/40kA 1250/2000A E class

#### • Top

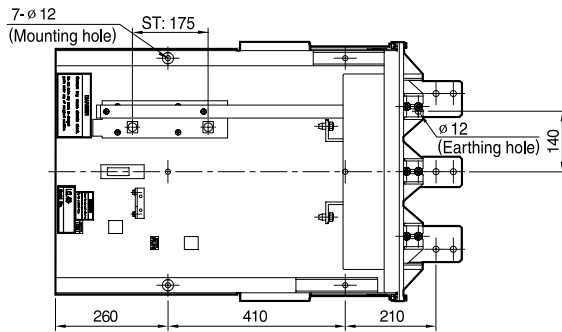

#### <Terminal conductor>

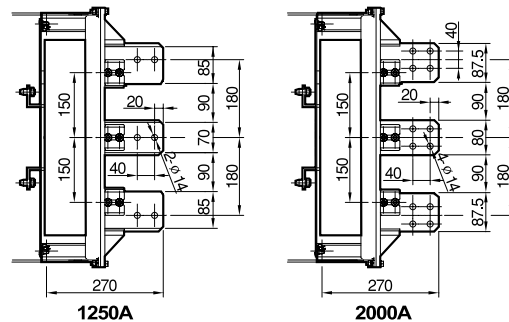

### LCL-06E-32D, 40D E class (Visible, Tulip contact) - (3150A)

#### • Front

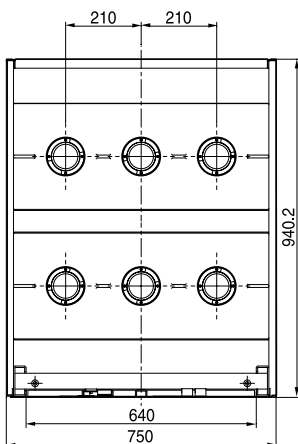

#### • Side

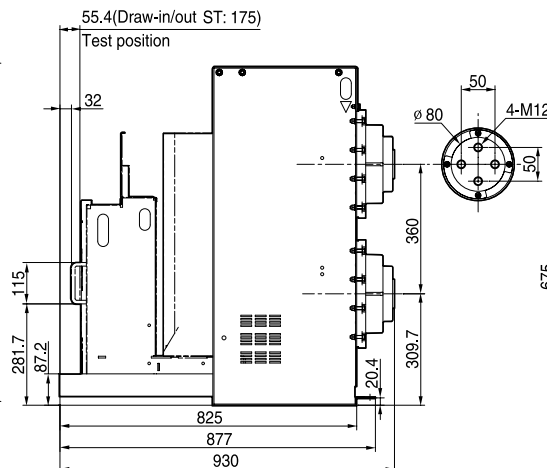

#### • Top

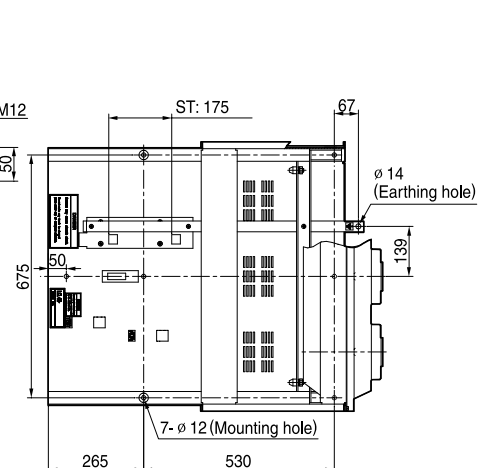



## LCL-06F-32D, 40D F class (Visible, Tulip contact) - (1250/2000A)

(Unit: mm)

• Front

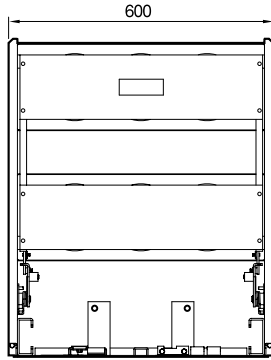

• Side

Rating	1250A	2000A
A	10	20

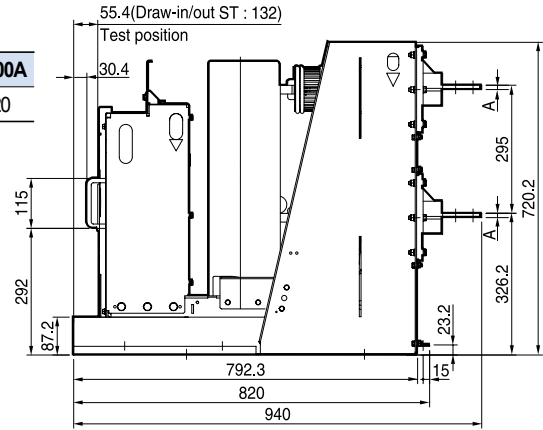

31.5/40kA 1250/2000A F class

<Terminal conductor>

• Top

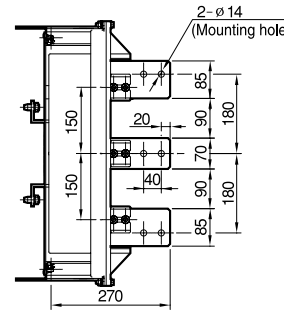
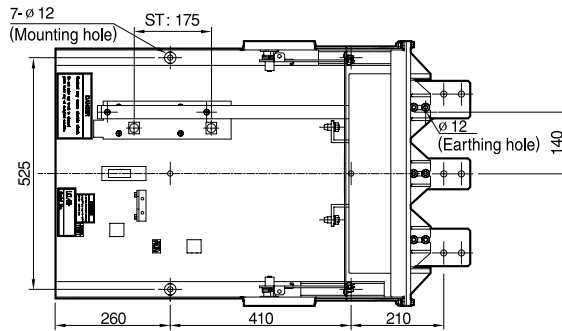

31.5/40kA 1250A F class

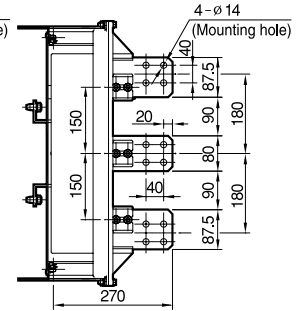

31.5/40kA 2000A F class

## LCL-06F-32D, 40D F class (Visible, Tulip contact) - (3150A)

• Front

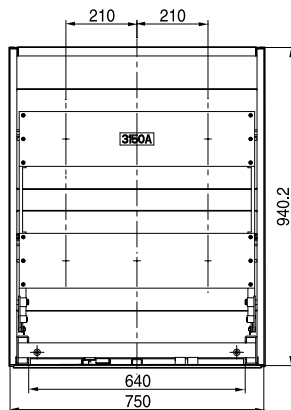

• Side

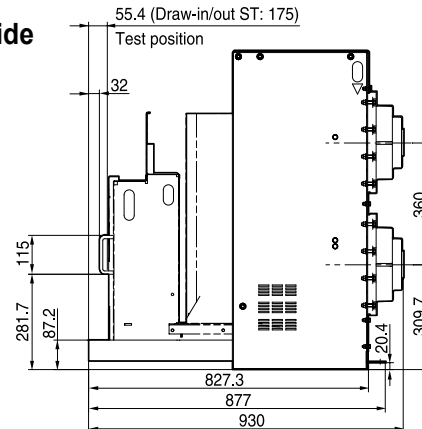

• Top

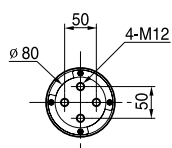

31.5/40kA 3150A F class

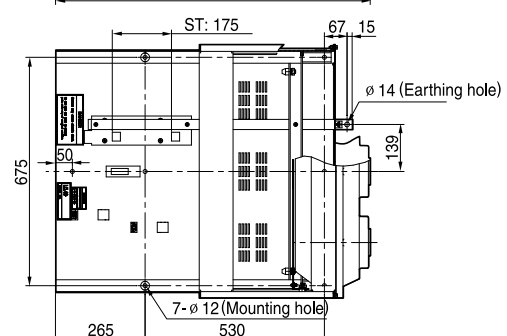

# Vacuum Circuit Breaker

## 7.2kV dimension (Cradle)

### LCL-06G-32D, 40D G class(Visible, Tulip contact) - (31.5/40kA 1250/2000A)

• Front

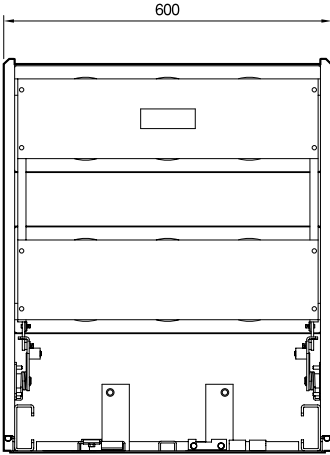

• Side

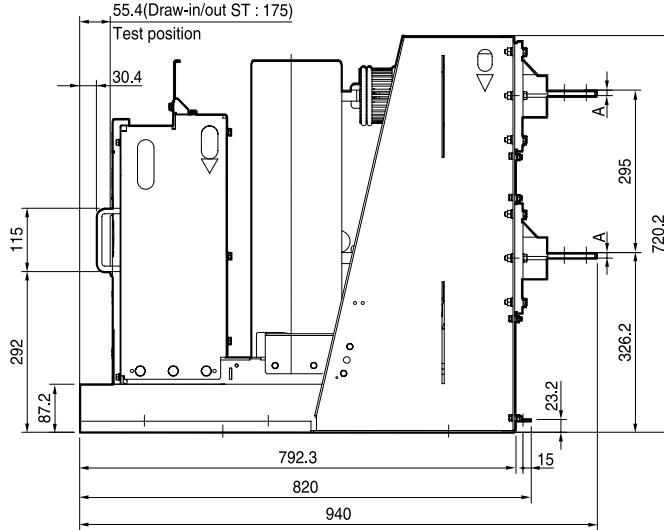

(Unit: mm)

31.5/40kA 1250/2000A G class

Rating	1250A	2000A
A	10	20

• Top

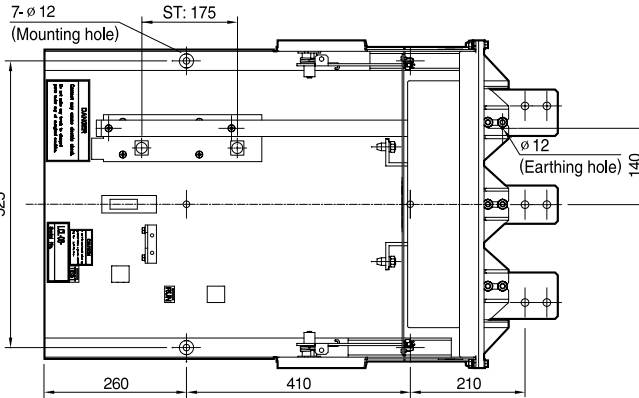

<Terminal conductor>

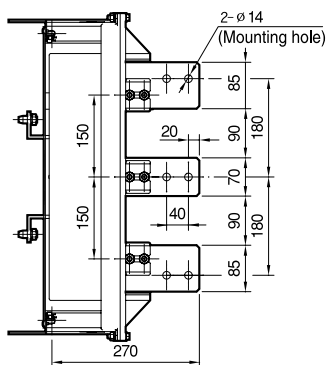

31.5/40kA 1250A G class

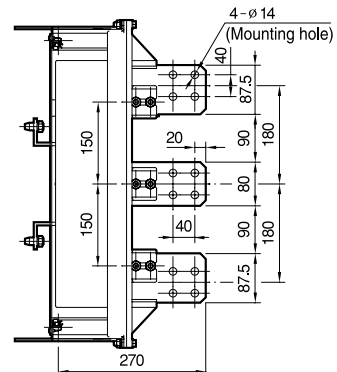

20-40kA 2000A G class

# LCL-06G-20D/T, 25D/T, 32D/T, 40D/T G class (Enclosed, Tulip contact) - (630/1250/2000A)

(Unit: mm)

• Front

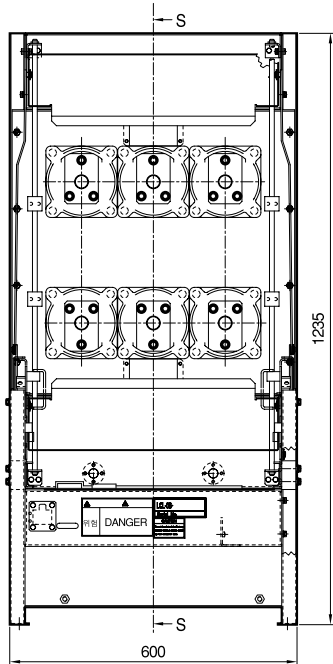

• Side

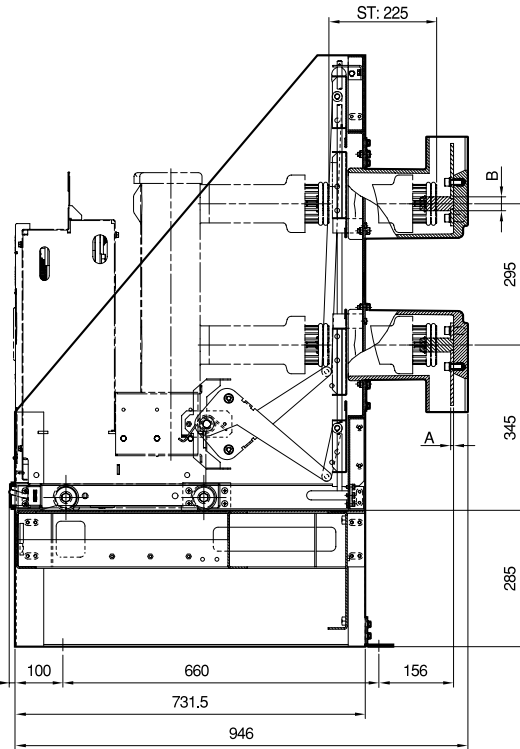

Section S-S

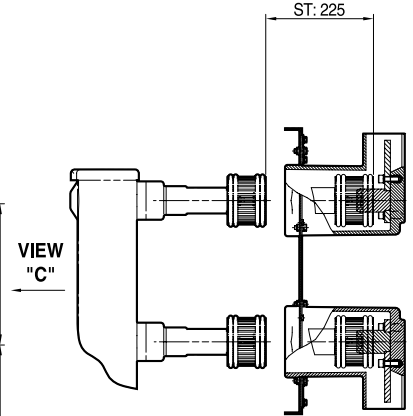

31.5/40kA 1250/2000A G class

• Top

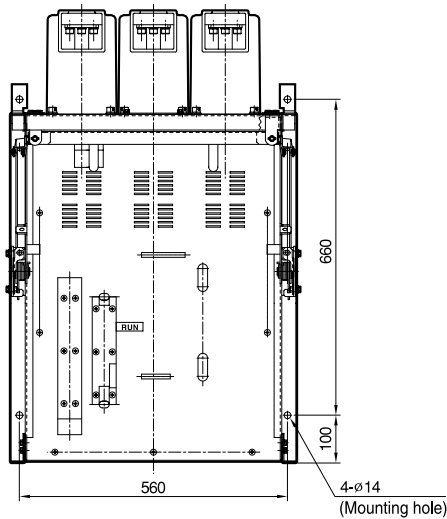

<Terminal conductor>

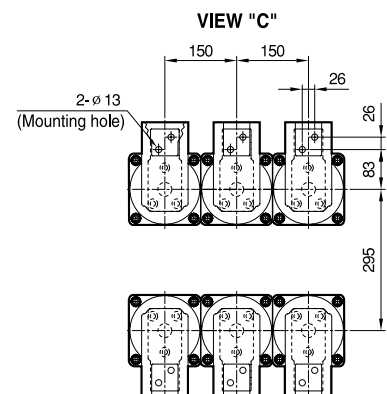

Rating	31.5/40kA	
	1250A	2000A
A	12	25
B	ø 48	

# Vacuum Circuit Breaker

## 7.2kV dimension (Cradle)

### LCL-06G-32D, 40D G class (Visible, Tulip contact) - (3150A)

(Unit: mm)

• Side

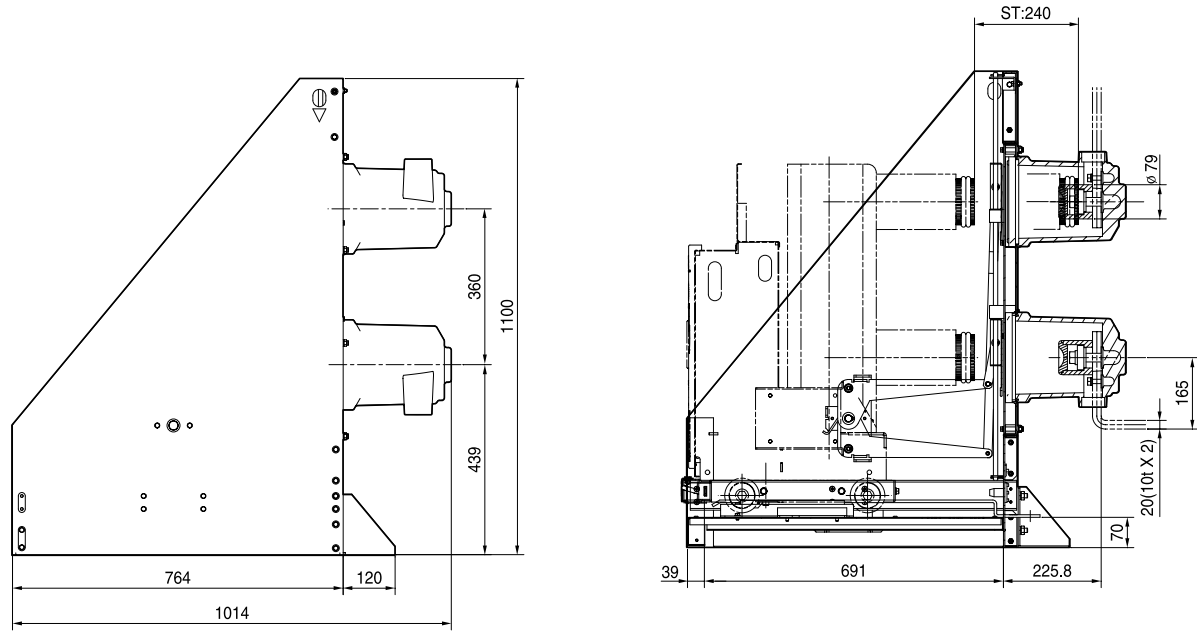

31.5/40kA 3150A G class

• Top

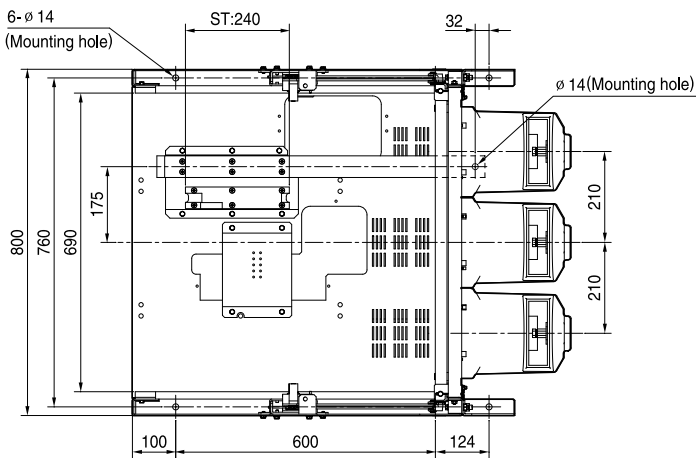

<User busbar requirement>

\*To connect with VCB 's bushing terminals user busbar should have below dimensions and two holes.

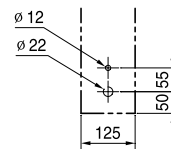

# 12kV dimension (VCB)



## LVB-12G-32D/T G class (Enclosed, Tulip contact) - (1250/2000A)

(Unit: mm)

• Front

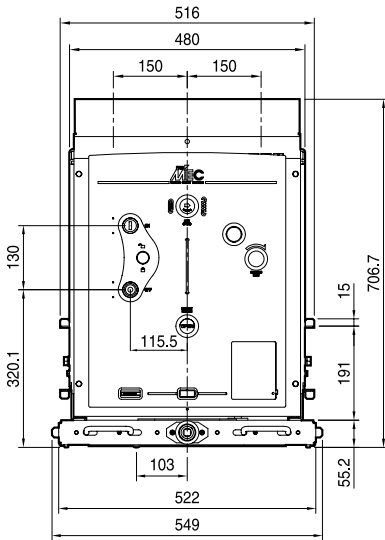

• Side

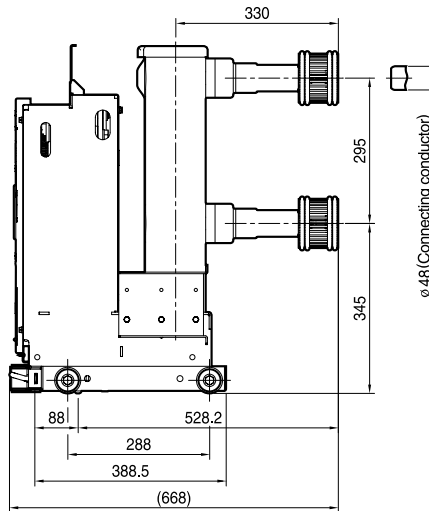

31.5kA 1250/2000A G class

## LVB-12G-40D G class (Enclosed, Tulip contact) - (1250/2000A)

• Front

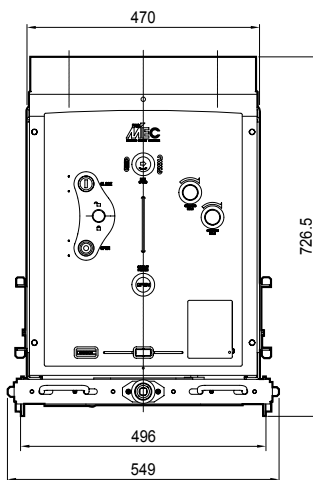

• Side

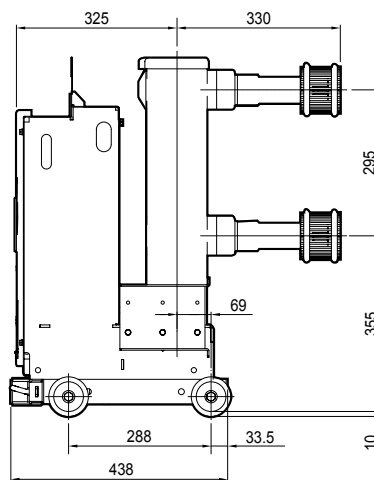

• Top

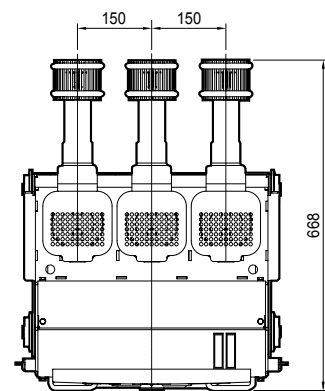

40kA 1250/2000A G class

# Vacuum Circuit Breaker

## 12kV dimension (VCB)

### LVB-12G-40D G class (Enclosed, Tulip contact) - (3150A)

(Unit: mm)

#### • Front

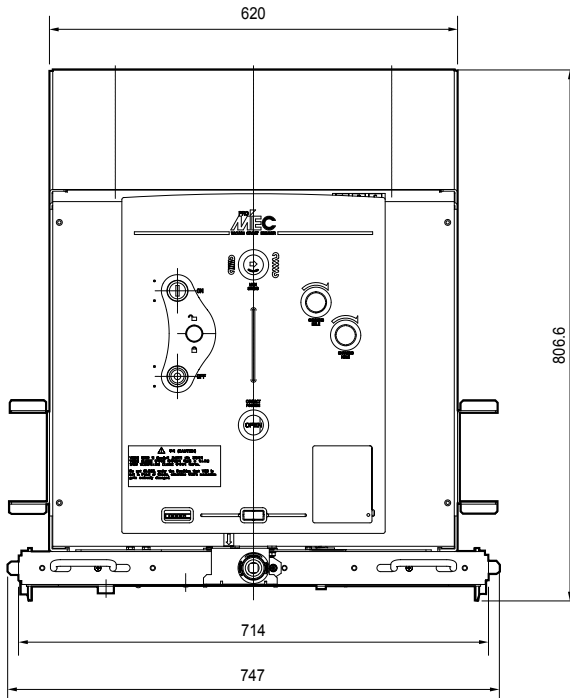

#### • Side

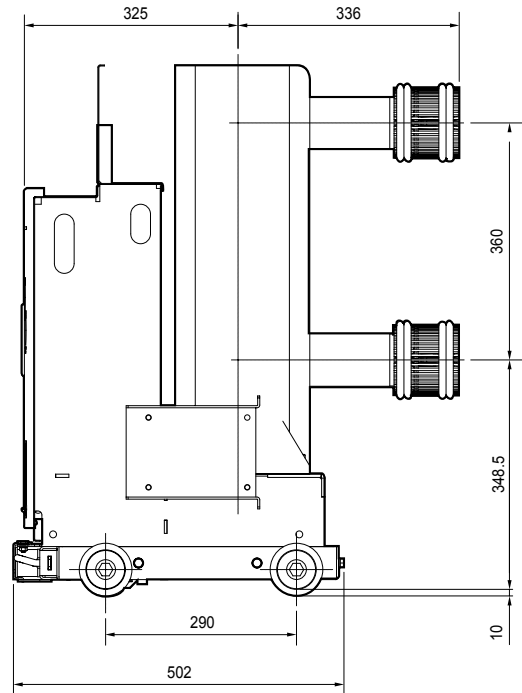

#### • Top

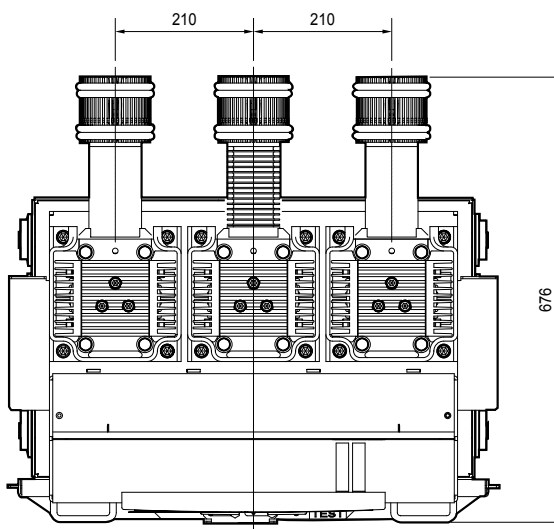

40kA 3150A G class

# 12kV dimension (Cradle)



## LCL-12G-25D/T, 32D/T G class (Enclosed, Tulip contact) - (630/1250/2000A)

(Unit: mm)

### • Front

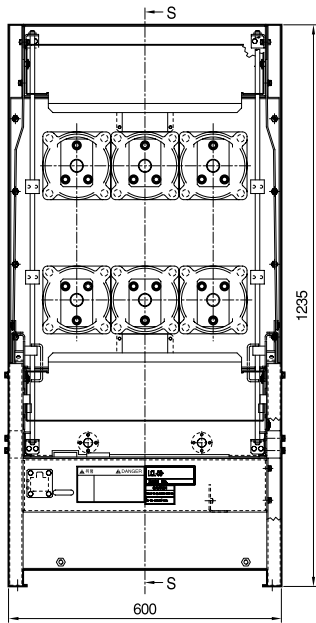

### • Side

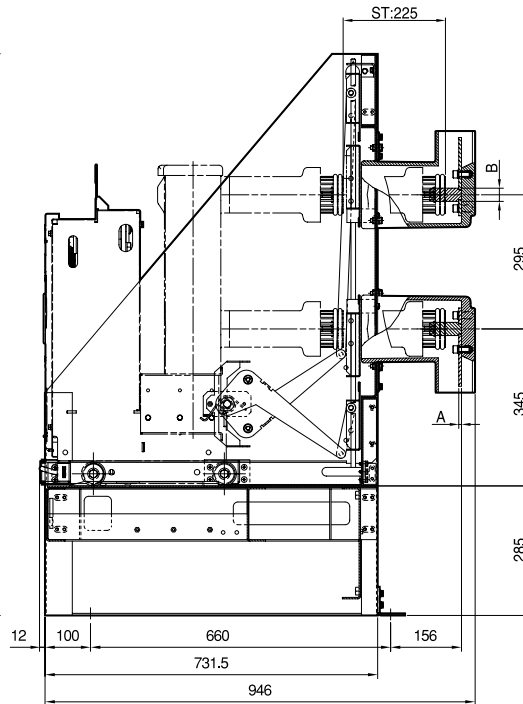

Section S-S

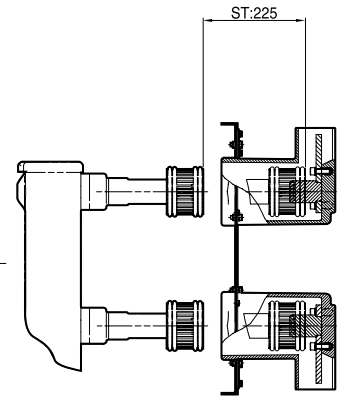

31.5kA 1250/2000A G class

### • Top

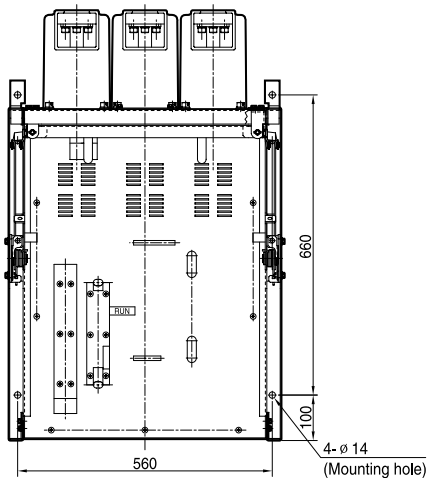

### <Terminal conductor>

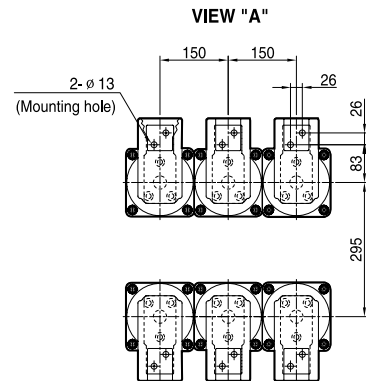

Rating	25kA	
	1250A	2000A
A	12	25
B	ø 48	

# Vacuum Circuit Breaker

## 12kV dimension (Cradle)

### LCL-12G-40D G class (Enclosed, Tulip contact) - (1250/2000A)

(Unit: mm)

#### • Front

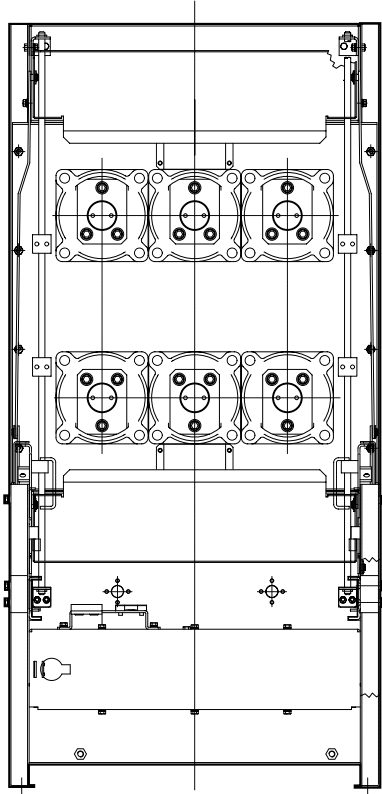

#### • Side

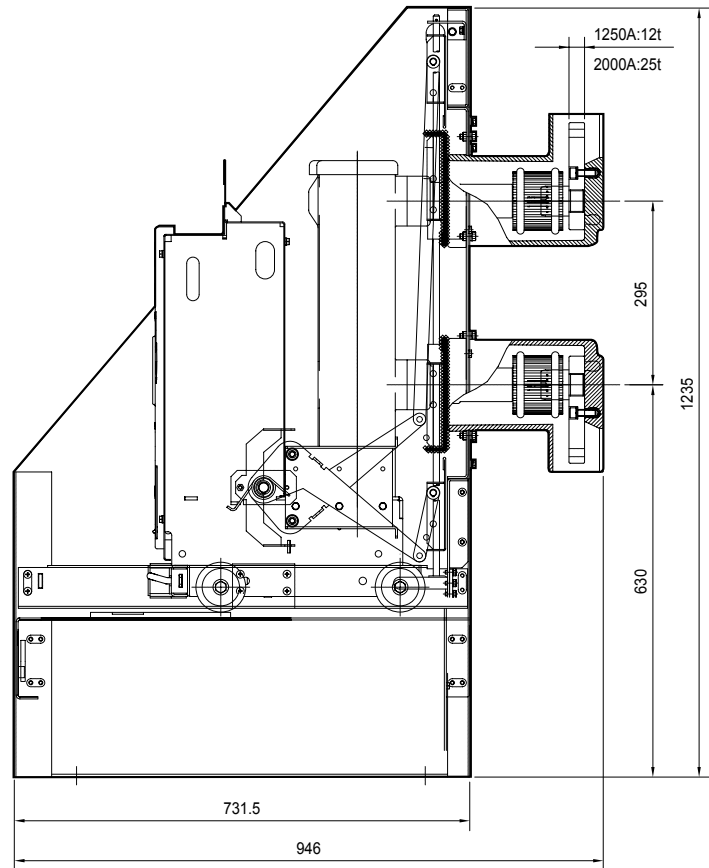

40kA 1250/2000A G class

#### • Top

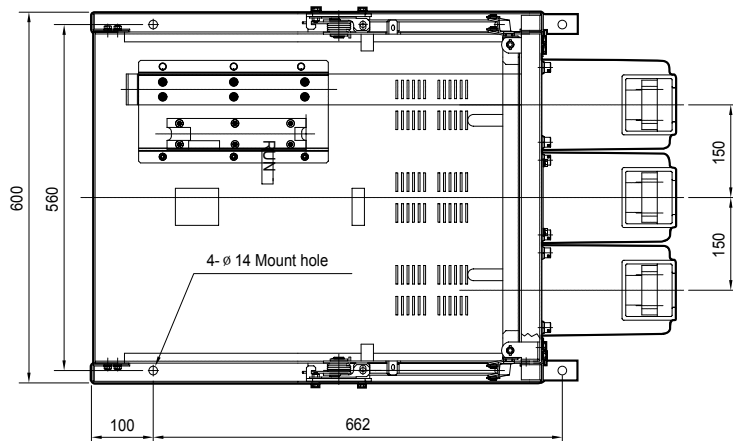

#### <Terminal conductor>

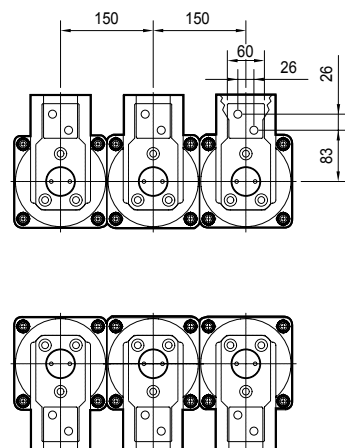



**LCL-12G-32D/LCL-12G-40D G class (Enclosed, Tulip contact) - (3150A)**

(Unit: mm)

• Front

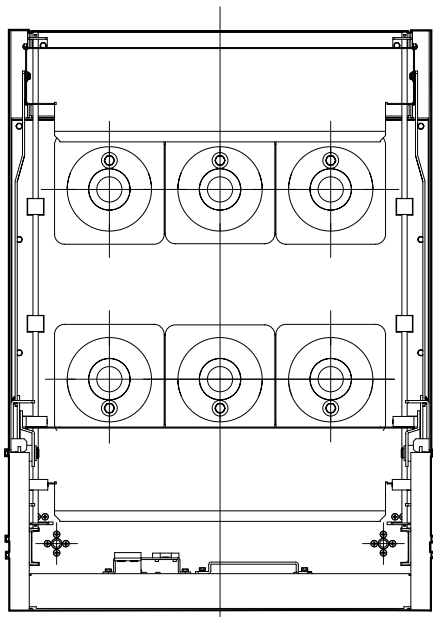

• Side

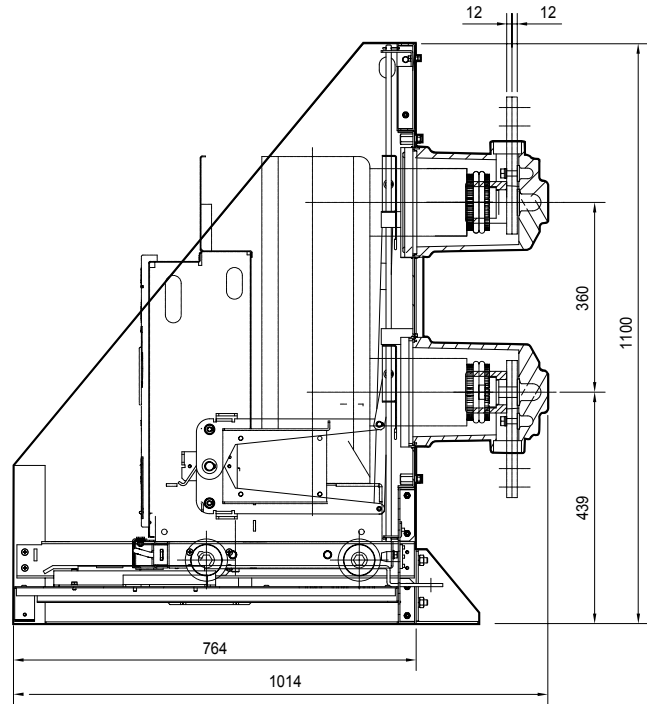

**40kA 3150A G class**

• Top

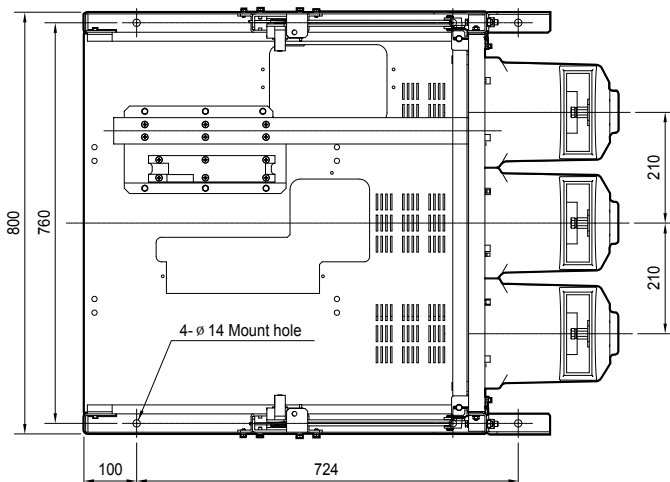

**<Terminal conductor>**

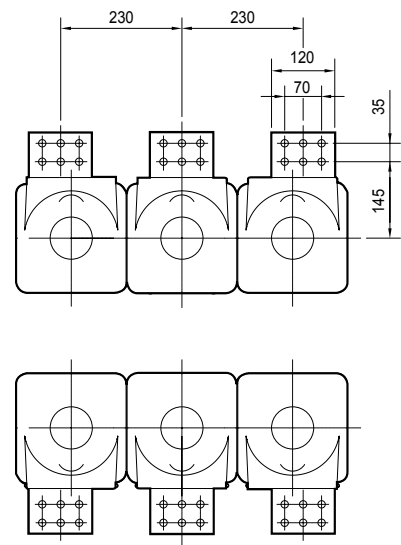

# Vacuum Circuit Breaker

## 17.5kV dimension (Cradle)

### LVB-17G-40D G class (Visible, Tulip contact) - (1250/2000A)

(Unit: mm)

• Front

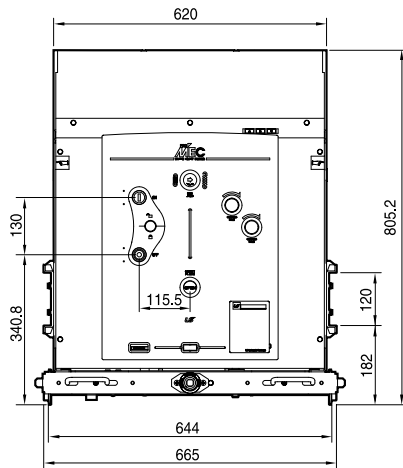

• Side

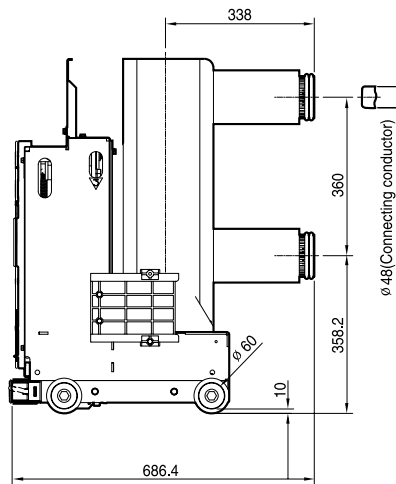

• Top

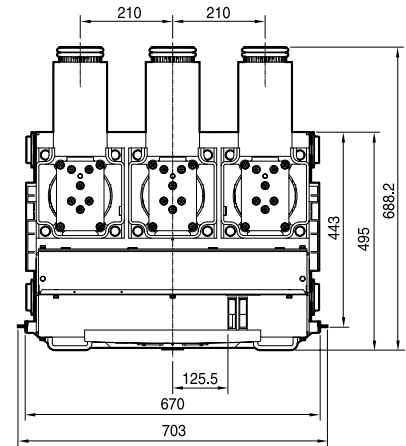

40kA1250/2000A G class

### LVB-17G-40D G class (Visible, Tulip contact) - (3150A)

• Front

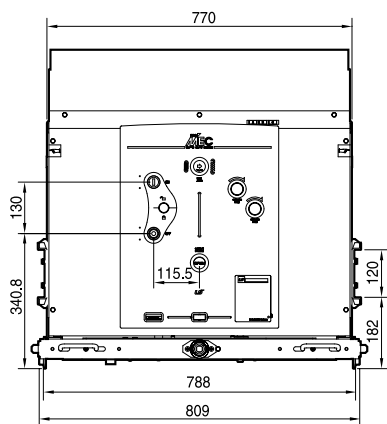

• Side

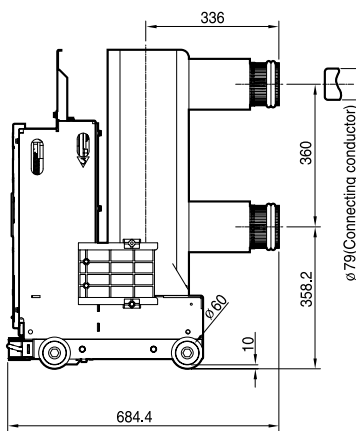

• Top

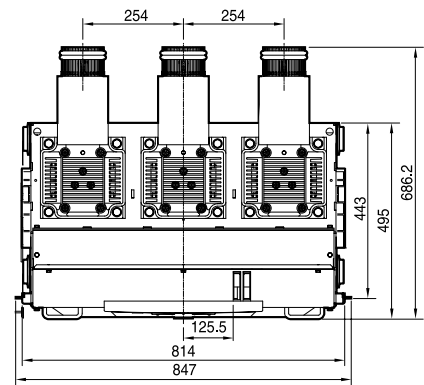

40kA 3150A G class

## LCL-17G-40D G class (Visible, Tulip contact) - (1250/2000A)

(Unit: mm)

• Side

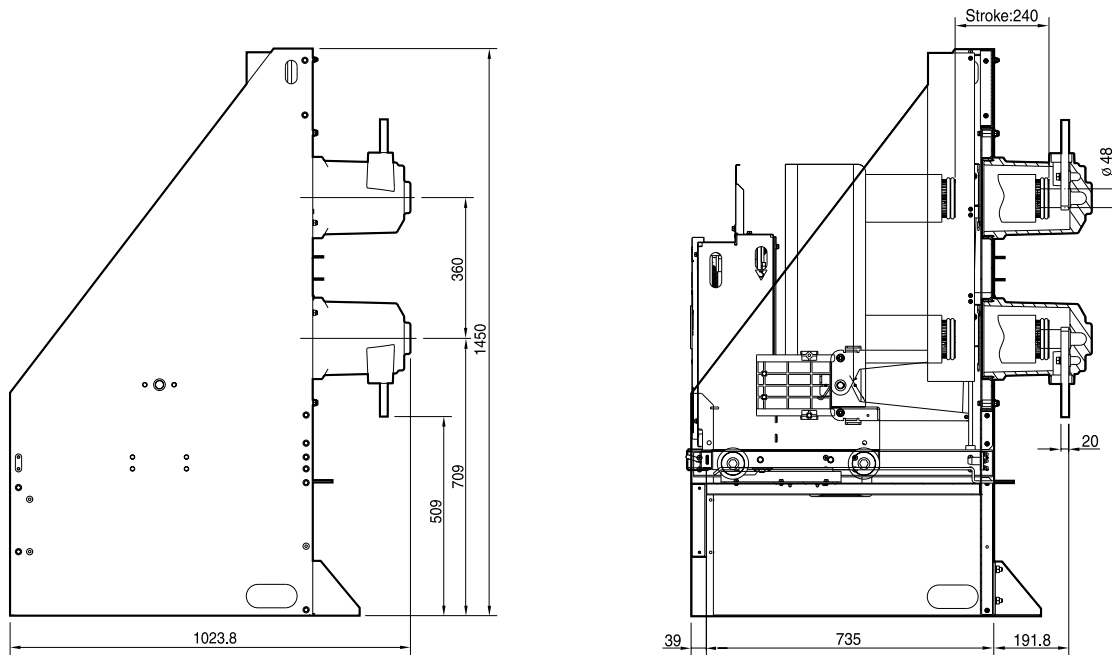

• Top

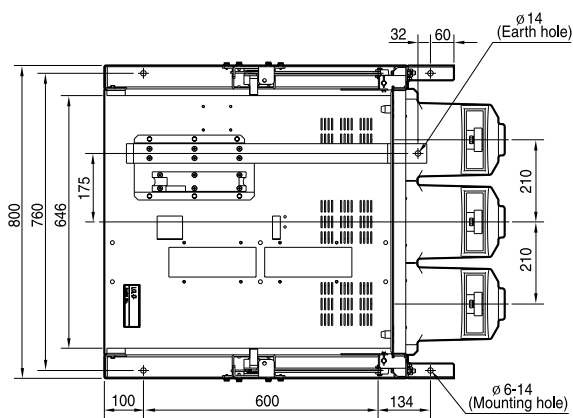

<Terminal conductor>

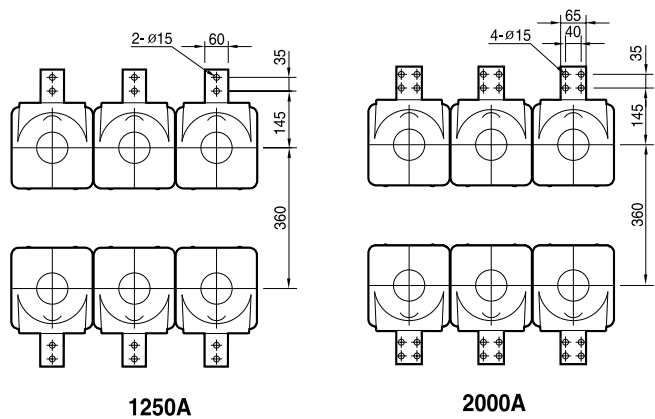

# Vacuum Circuit Breaker

## 17kV dimension (VCB)

### LCL-17G-40D G class (Visible, Tulip contact) - (3150A)

(Unit: mm)

#### • Side

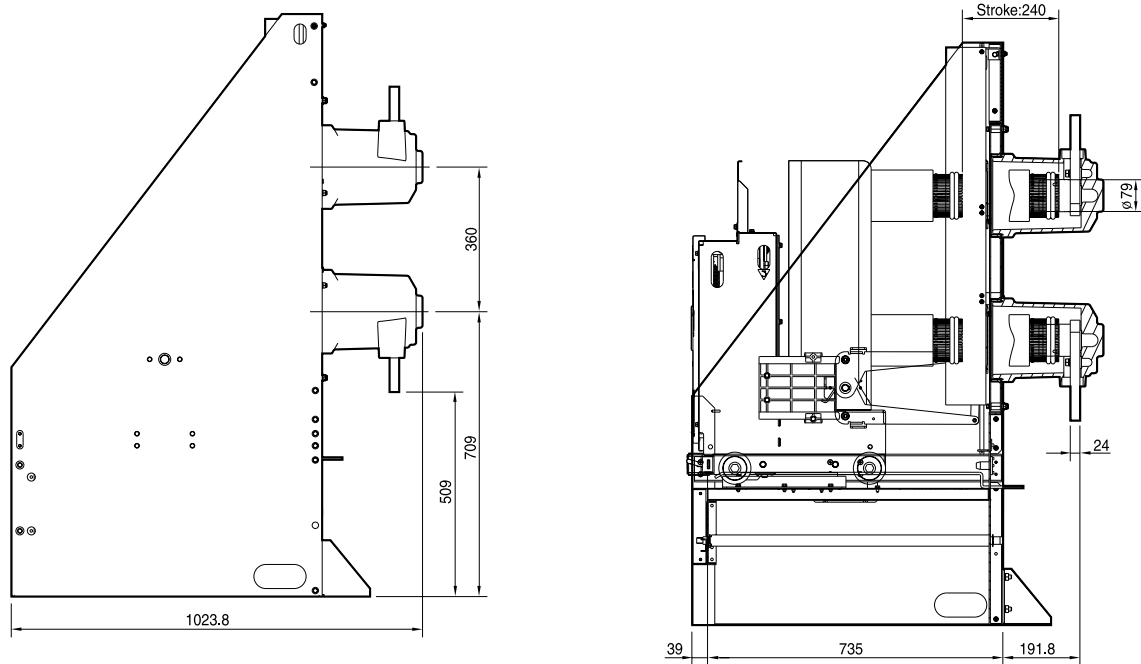

#### • Top

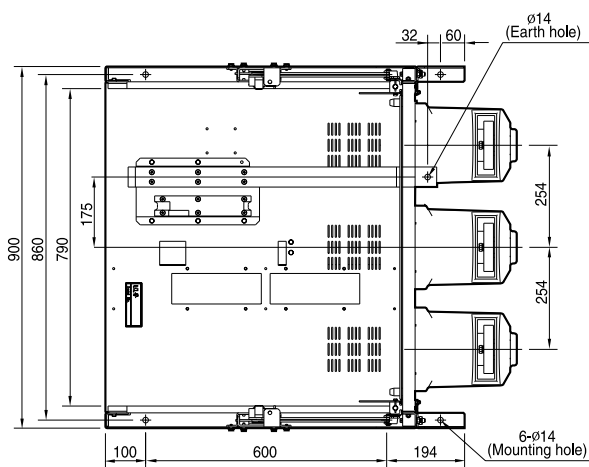

#### <Terminal conductor>

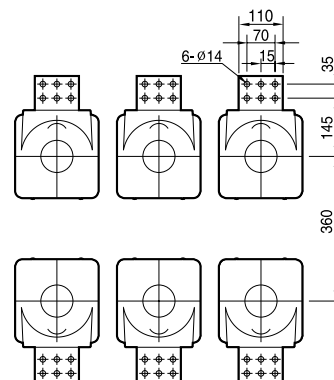

## LVB-20P-13D, 16D, 25D (Visible, Fixed) - (630/1250/2000A)

(Unit: mm)

• Front

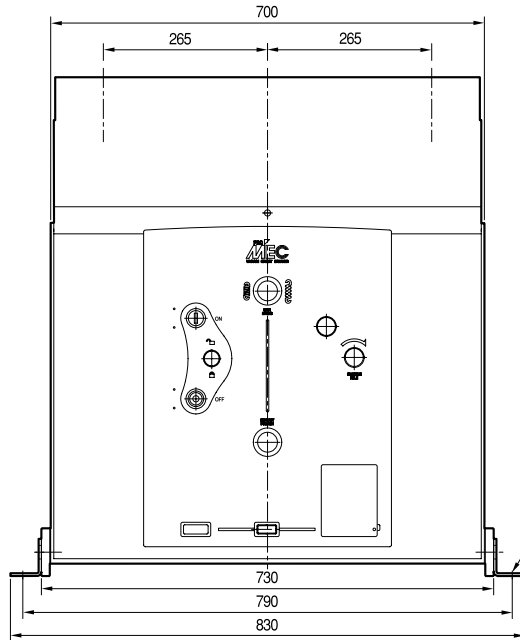

• Side

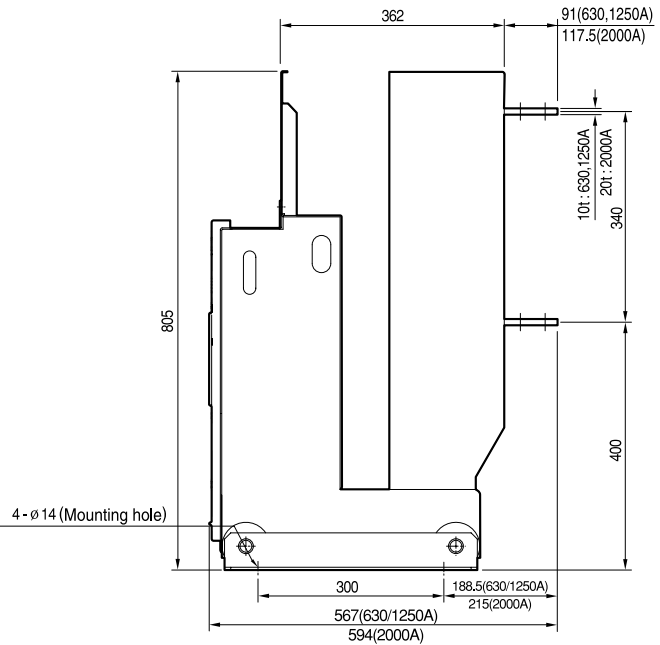

### <Terminal conductor>

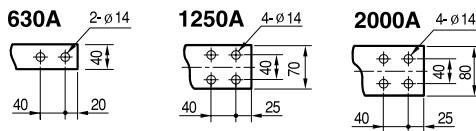

## LVB-20E, F-13D/(T), 16D/(T), 25D/(T) E, F class - (630/1250/2000A)

• Front

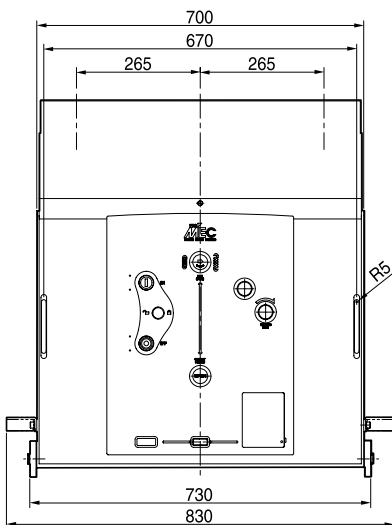

• Side

### <Visible, Clip contact>

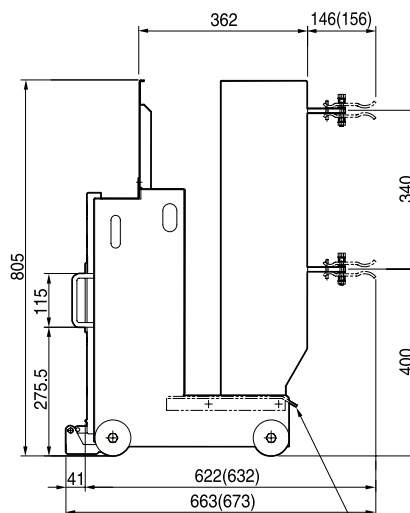

### <Enclosed, Tulip contact>

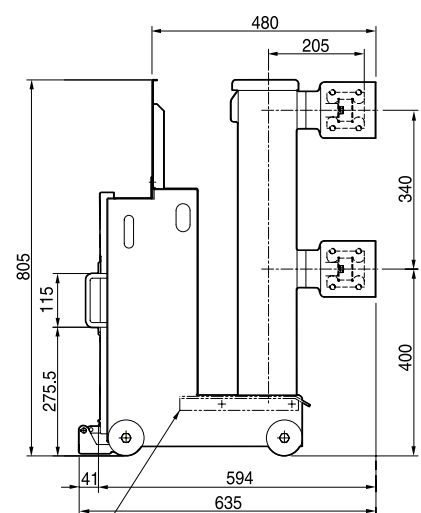

It will be installed at F class cradle in both side.

Note ) In case of 12.5kA & 16kA 630A, the dimension shown in parenthesis should be applied.

# Vacuum Circuit Breaker

## 24kV dimension (VCB)

### LVB-20G-13D, 16D, 25D G class (Visible, Tulip contact) - (630/1250A)

(Unit: mm)

#### • Front

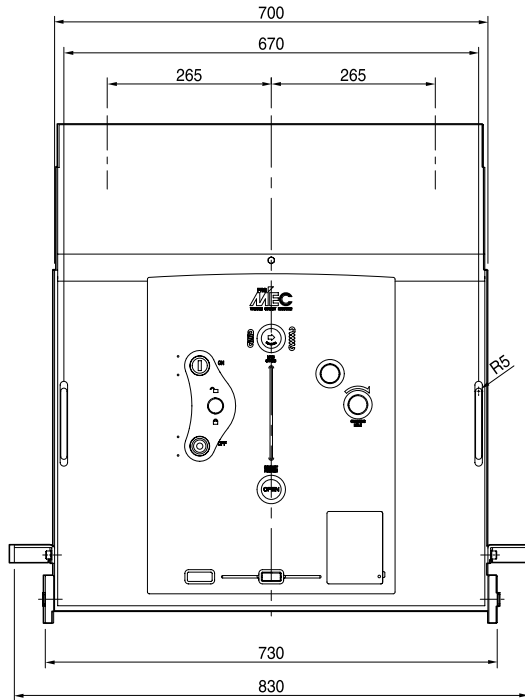

#### • Side

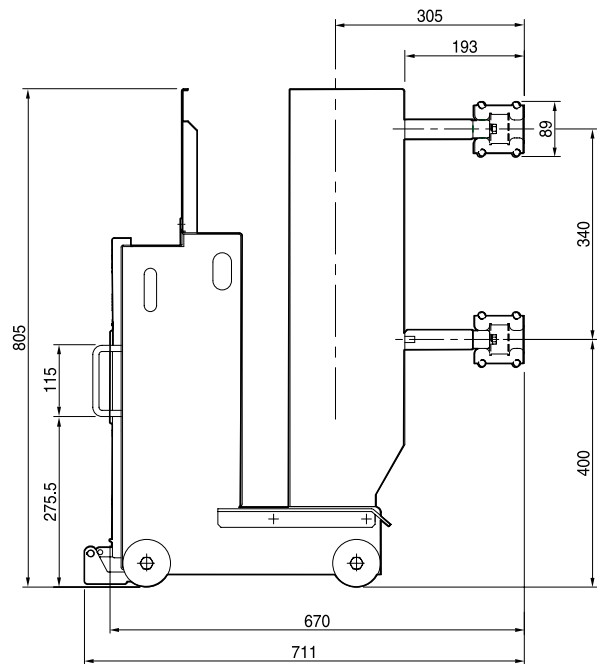

### LVB-20G-13D/T, 16D/T, 25D/T G class (Enclosed, Tulip contact) - (630/1250/2000A)

#### • Front

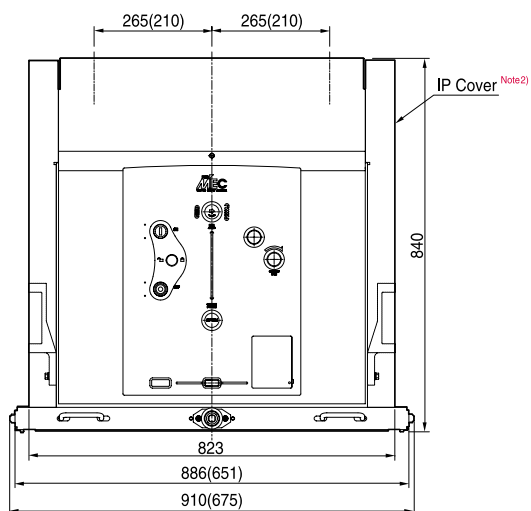

#### • Side

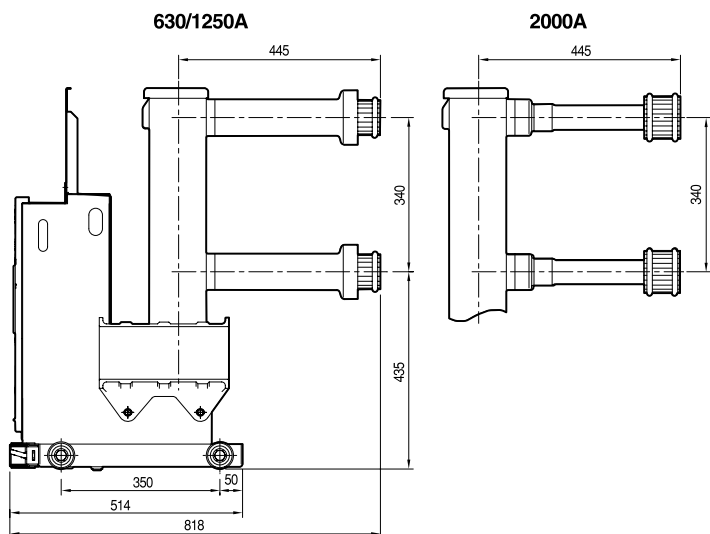

Note 1) ( ): The dimension shown in parenthesis should be applied to LVB-20G-13E/T or LVB-20G-16E/T, LVB-20G-25E/T for 630A and 1250A in case that distance between phase & phase is 210mm.

2) IP Cover applied both sides in case of 265mm phase distance.

# 24kV dimension (Cradle)



## LCL-20E-13D, 16D, 25D E class (Visible, Clip contact) - (630/1250/2000A)

(Unit: mm)

### • Front

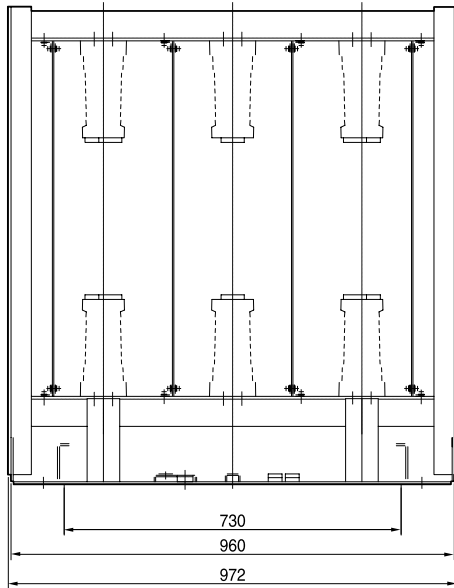

### • Side

Rating	A	B	T
630, 1250A	768	190.5	10
2000A	778	185.5	20

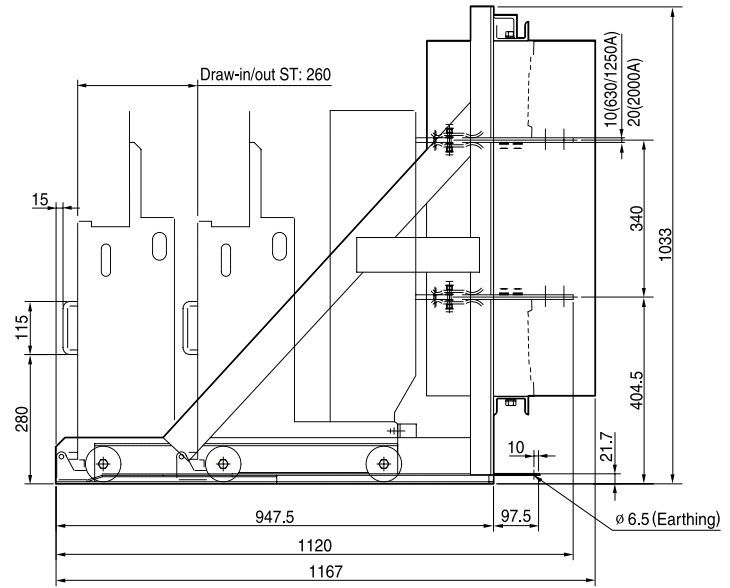

### • Top

### <Terminal conductor>

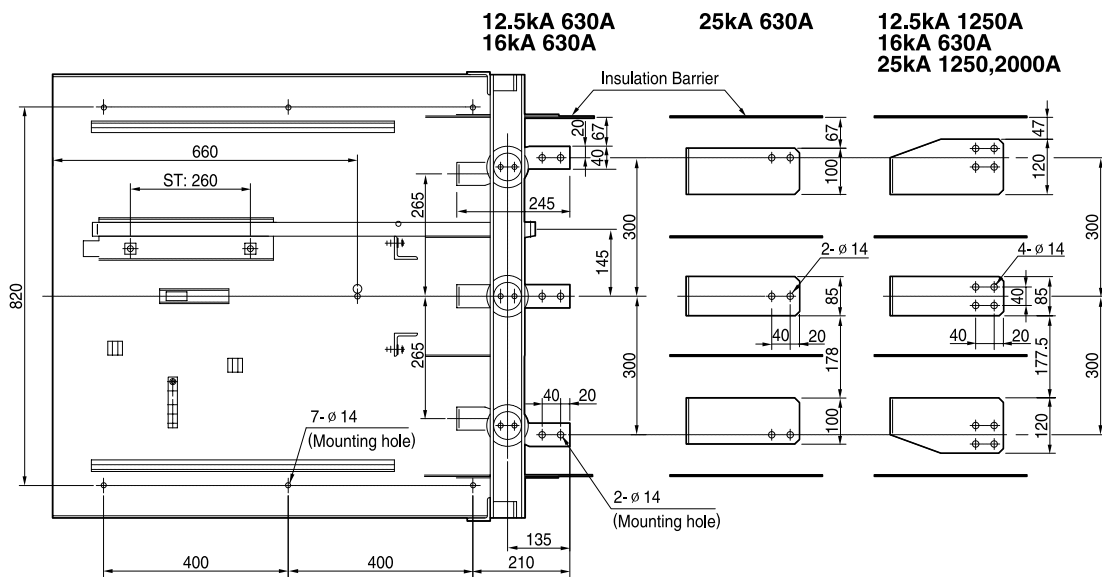

Note) Insulation barrier is not used for rating 12.5kA 630A and 16kA 630A

# Vacuum Circuit Breaker

## 24kV dimension (Cradle)

### LCL-20E-13D/T, 16D/T, 25D/T E class (Enclosed, Tulip contact) - (630/1250/2000A)

(Unit: mm)

#### • Front

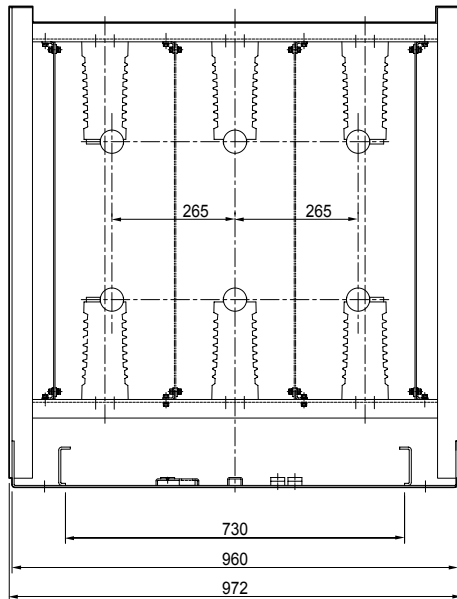

#### • Side

Rating	A	B	T
630, 1250A	768	190.5	10
2000A	778	185.5	20

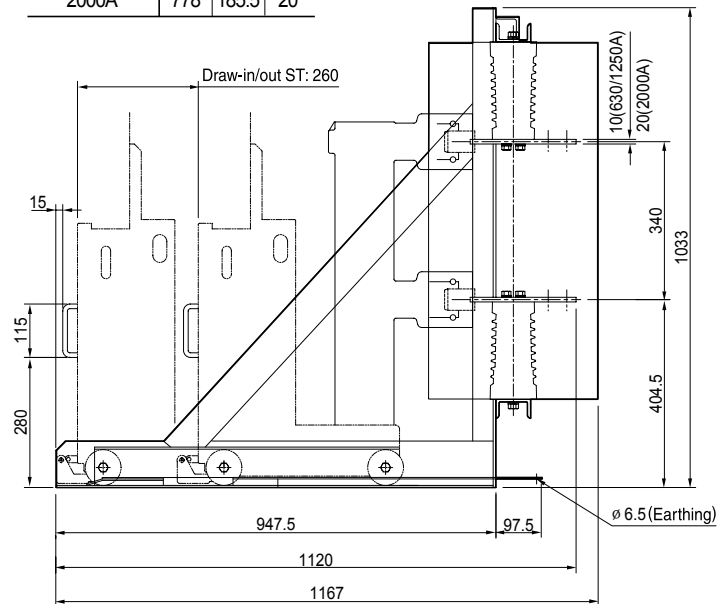

#### • Top

#### <Terminal conductor>

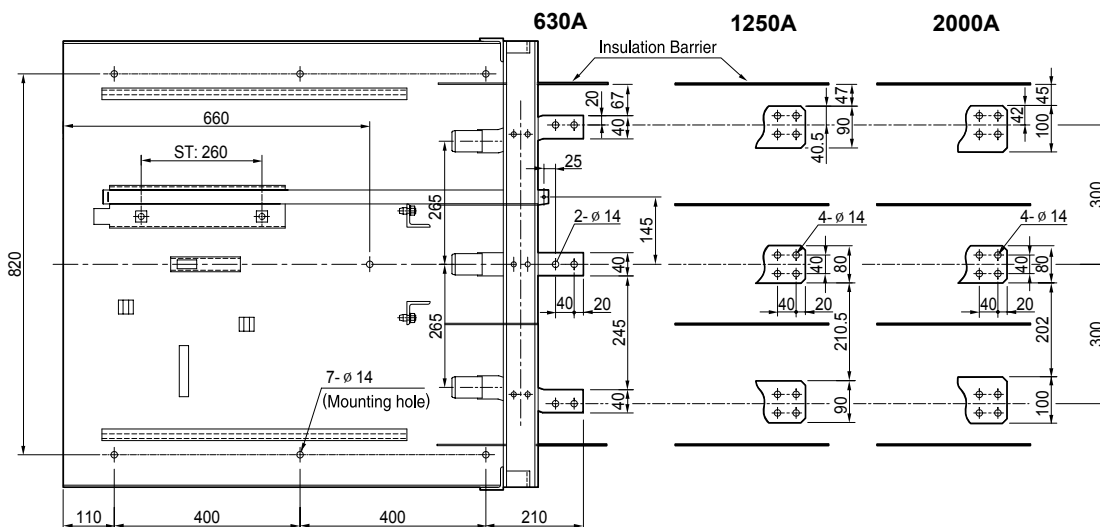

Note) Insulation barrier is not used for rating 12.5kA 630A and 16kA 630A



# LCL-20F-13D, 16D, 25D F class (Visible, Clip contact) - (630/1250/2000A)

(Unit: mm)

• Front

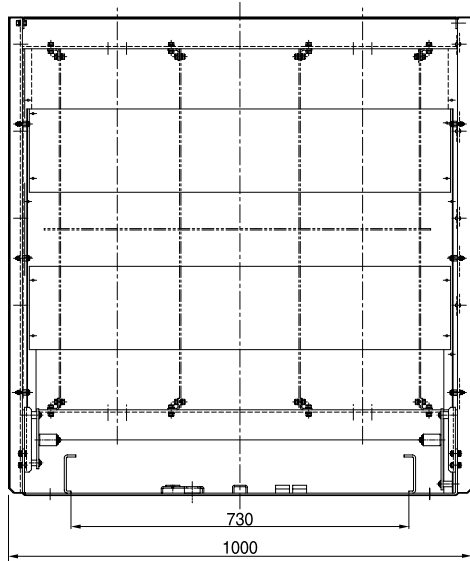

• Side

Rating	A	B	T
630, 1250A	768	190.5	10
2000A	778	185.5	20

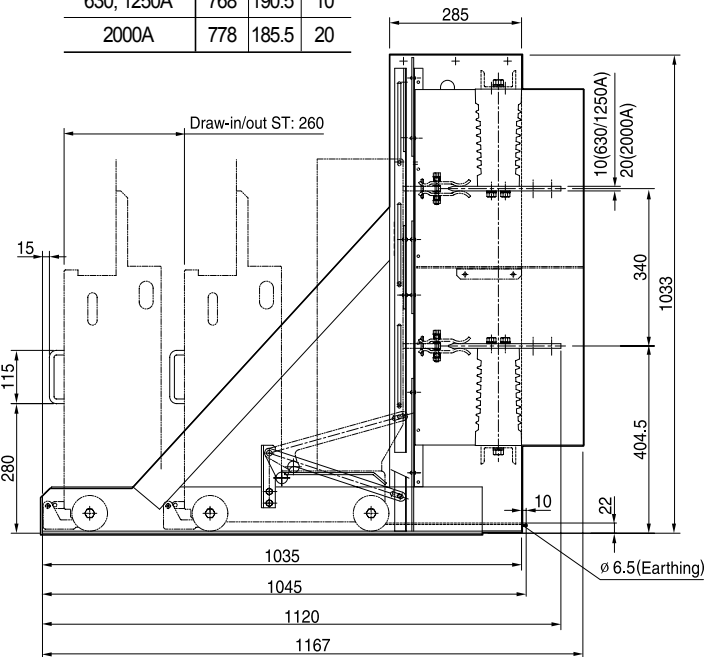

<Terminal conductor>

• Top

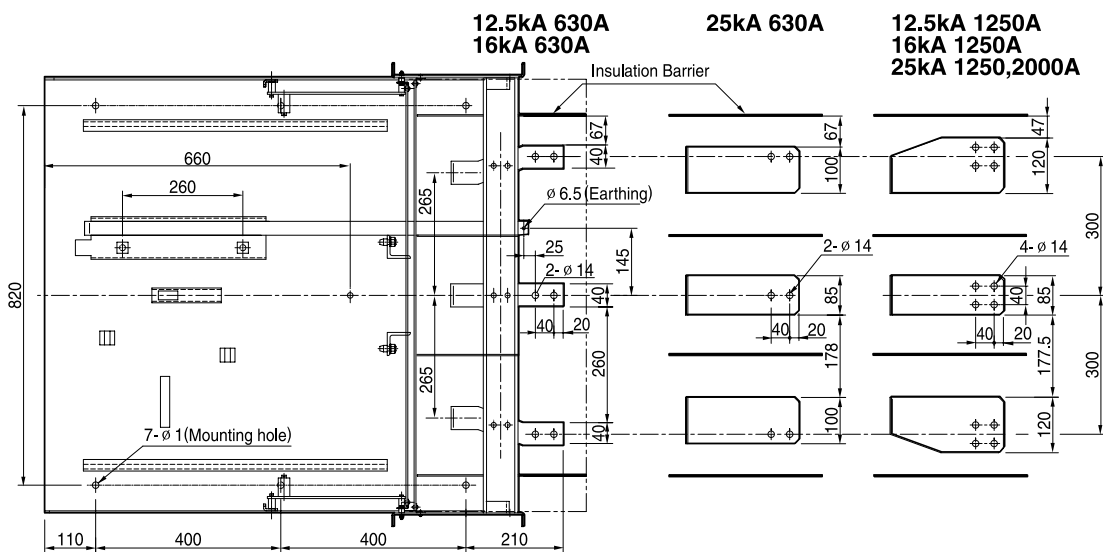

Note) Insulation barrier is not used for rating 12.5kA 630A and 16kA 630A

# Vacuum Circuit Breaker

## 24kV dimension (Cradle)

### LCL-20F-13D/T, 16D/T, 25D/T F class(Enclosed, Tulip contact) - (630/1250/2000A)

(Unit: mm)

#### • Front

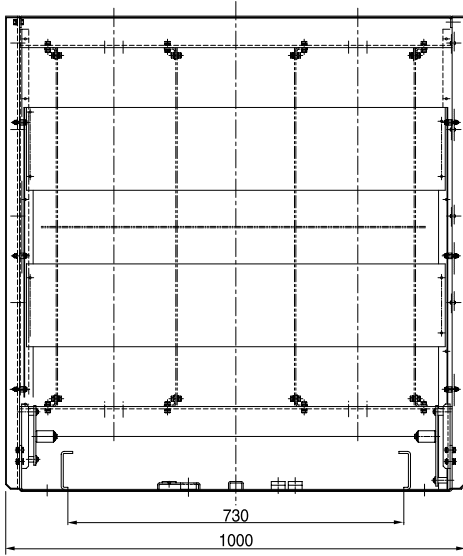

#### • Side

Rating	A	B	T
630, 1250A	768	190.5	10
2000A	778	185.5	20

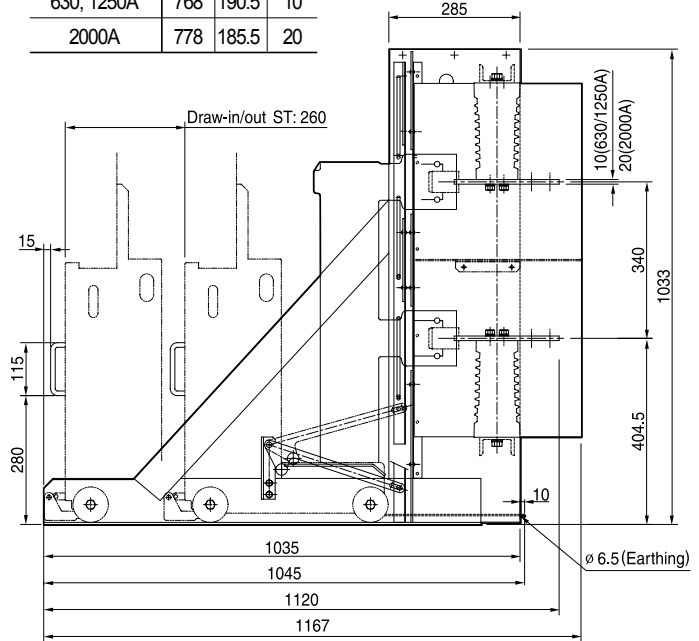

#### <Terminal conductor>

#### • Top

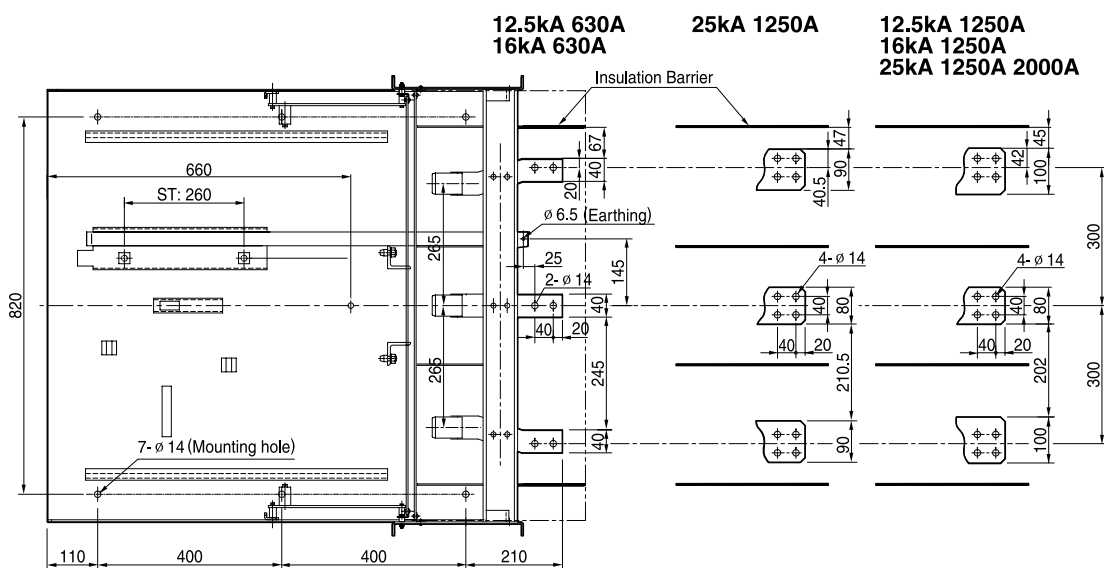

Note) Insulation barrier is not used for rating 12.5kA 630A and 16kA 630A

# LCL-20G-13D, 16D, 25D G class (Visible, Tulip contact) - (630/1250A)

(Unit: mm)

• Front

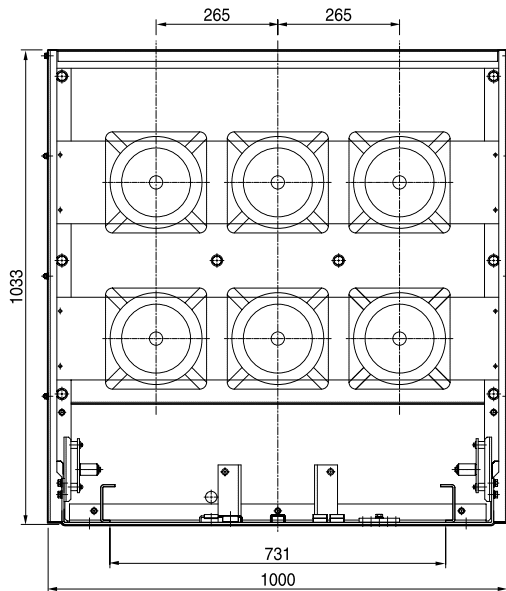

• Side

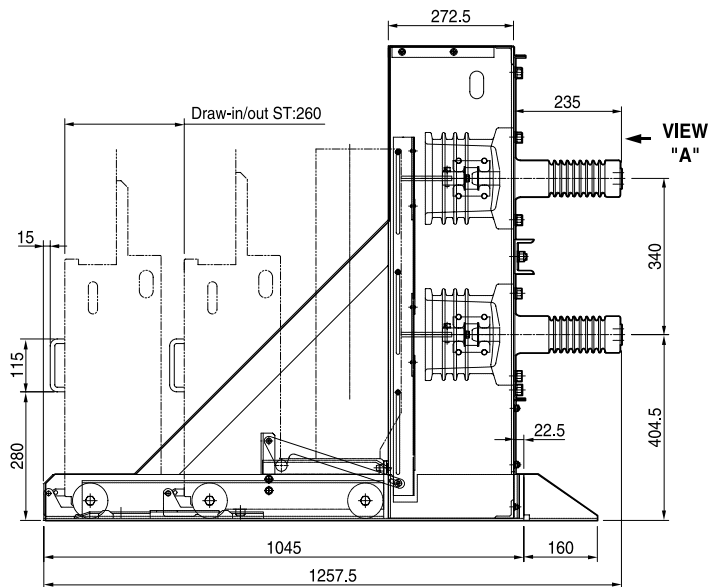

• Top

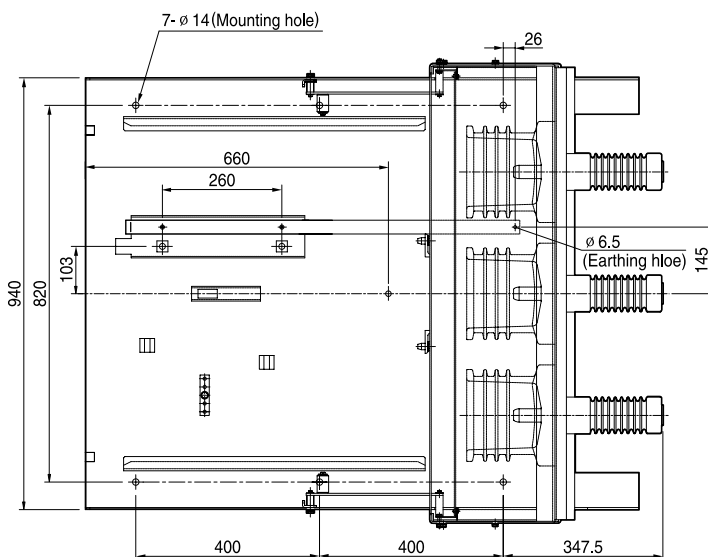

<Terminal conductor>

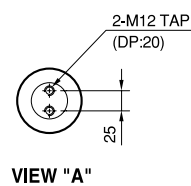

# Vacuum Circuit Breaker

## 24kV dimension (Cradle)

### LCL-20G-13D/T, 16D/T, 25D/T G class (Enclosed, Tulip contact) - (630/1250/2000A)

(Unit: mm)

#### • Front

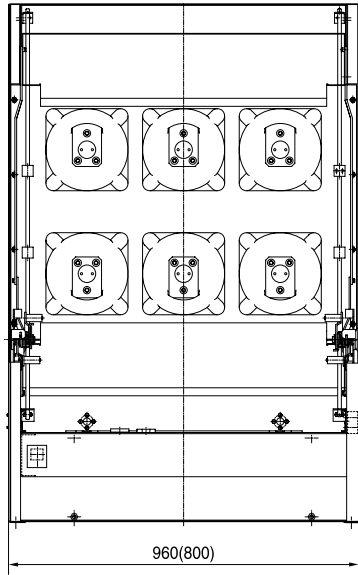

#### • Side

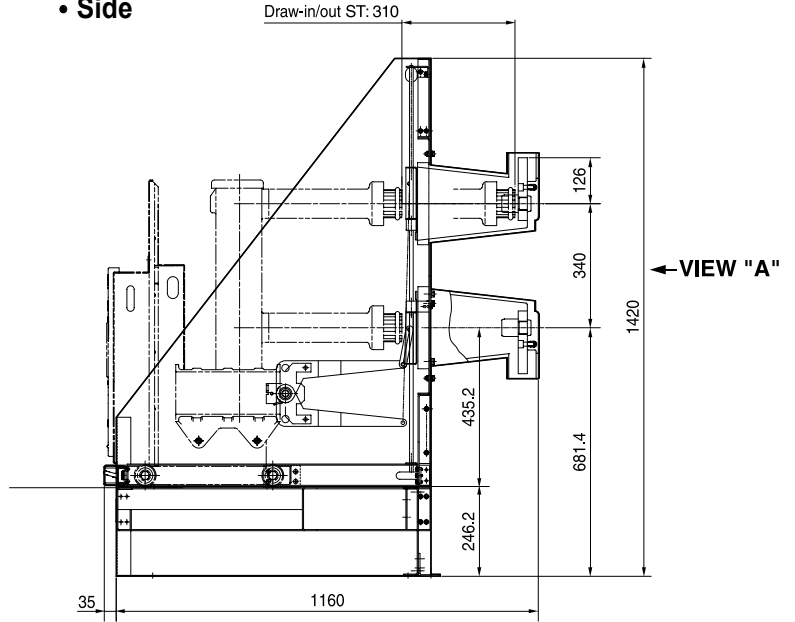

#### • Top

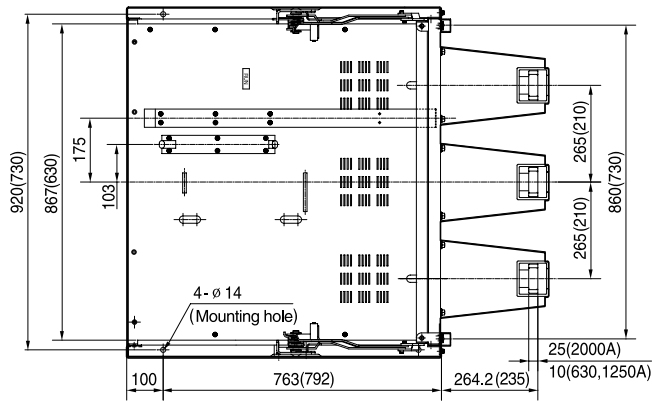

#### <Terminal conductor>

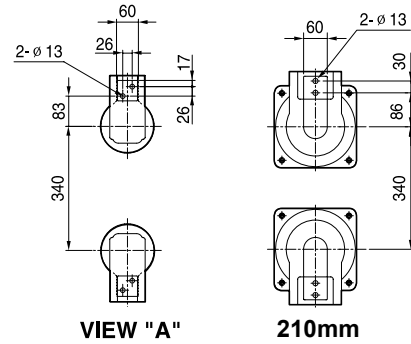

Note ( ) : The dimension shown in parenthesis should be applied to LVB-20G-13E/T or LVB-20G-16E/T, LVB-20G-25E/T for 630A and 1250A in case that distance between phase & phase is 210mm.

#### • Earthing Switch

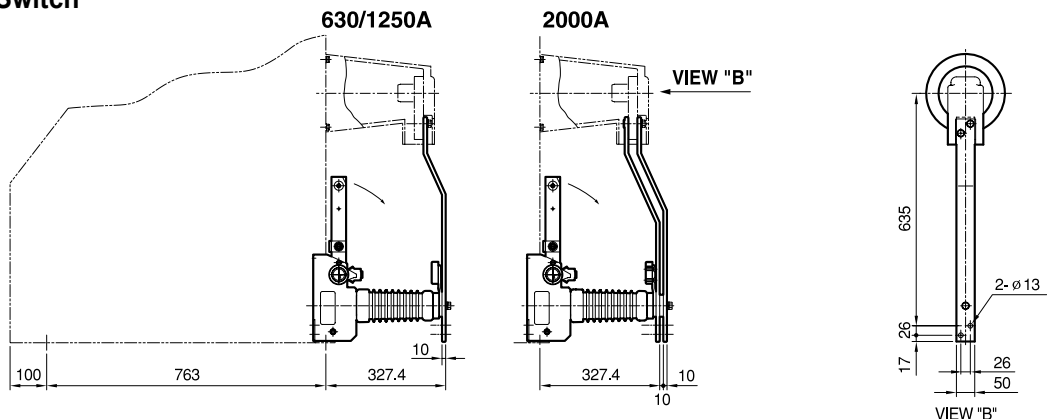

## Accessories for VCB

### Key lock

When it is locked by a key, the closing operation is not available (electrically and mechanically) without a Key.



### Button padlock

Button padlock protects 'ON' or 'OFF' button when accident is occurred by operation at discretion.

It is available to operate after release button padlock.

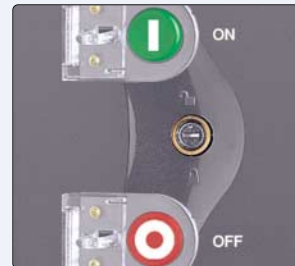

### Button cover

Button cover protects 'ON' or 'OFF' button when accident is occurred by operation at discretion. It is available to operate by push bar.



### Position switch (Cell switch)

Indicating the position (Run or Test) of a VCB, by mechanically pressing the switch when a VCB change the position.

- RUN: 2a
- TEST: 2a

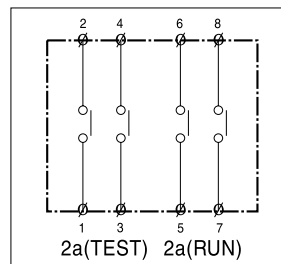

Note) In case that position of VCB changed to "Run" or "Test" position, "a" contact will be closed.



# Vacuum Circuit Breaker

## Accessories

### Accessories for VCB

#### Secondary coil (Preparatory trip coil)

The main coil and the preparatory coil is connected in parallel. So even though there happens a fault in the trip coil, the VCB can be tripped by one of the two trip coils.

#### Latch checking switch

When the Latch is in abnormal position, the Latch checking switch prevents the closing operation even though there is the 'Closing' signal.

#### Charge indicator

Remotely indicates the charging is completed.  
(Standard Feature)  
- Terminal No.: 9, 10

#### Position padlock

The hole to prevent the draw-in and out of a VCB from the present position. ('Run' or 'Test')  
Standard option in the interlock lever of the E, F class draw-out type VCB. (Hole size =  $\varnothing$  8)

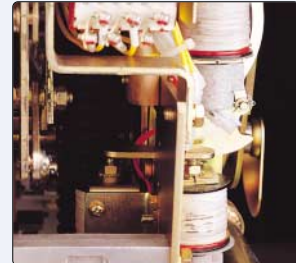

## Accessories for Cradle

### Earthing switch (for G class draw-out type only)

For the safety during the maintenance of a VCB panel, discharge the charging current in the load side of a VCB with this earthing switch.

### Padlock of earthing switch (for G class draw-out type only)

To prevent the accident through carelessness earthing switch operation, the locking of the earthing switch is available when the switch is in 'OFF' position.

(Hole size =  $\varnothing 8$ )

### Position switch of the earthing switch (for G class draw-out type only)

Indicates the 'ON' or 'OFF' status of the earthing switch. (5a5b)

### Locking coil of earthing switch (for G class draw-out type only)

To prevent the accident through carelessness earthing switch operation, the earthing switch can be changed to 'ON' position after releasing the lock by magnetizing the coils.

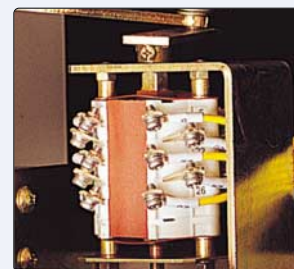
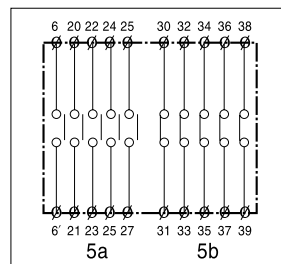

<Earthing Switch Position Switch>



<Earthing Switch Locking Coil>

# Vacuum Circuit Breaker

## Accessories

### Accessories for Cradle

#### Shutter padlock

The hole to lock the shutters (load and line side) in close position, to increase the safety during the maintenance of a VCB draw-out position.

(Hole size =  $\varnothing 8$ )

#### Mechanically operated cell switch (MOC)

##### -for G class draw-out type only

The auxiliary switch (3a4b), which indicate the 'ON' or 'OFF' condition of a VCB, but operated only when the VCB is in 'Run' state. (Installed in the bottom of a cradle)

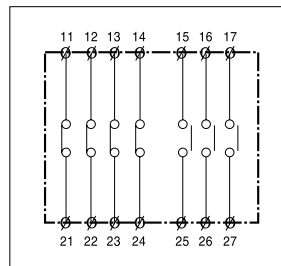

Note) #11, 21 are Early "b" contact

#### Truck operated cell switch (TOC)

##### -for G class draw-out type only

The auxiliary switch (3a4b), which indicate the 'Run' state of a VCB and is operated by the movement of a VCB frame. (Installed in the bottom of a cradle)

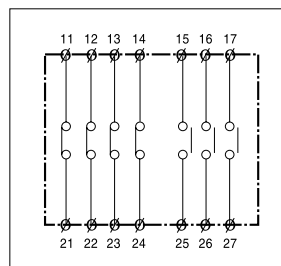

Note) #11, 21 are Early "b" contact

#### Code plate (Miss insertion prevention)

##### -for E, F class draw-out type only

To prevent the insert a VCB to a cradle, when the ratings of VCB and cradle are different.

#### Padlock

To prevent the insert draw-in/out handle to a screw hole by operating G class VCB temporarily

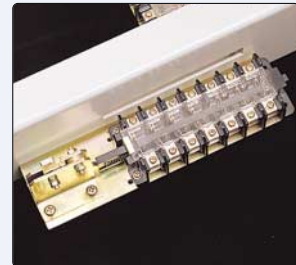



## Optional accessories

### Capacitor trip device (CTD)

When the control power is off, the CTD supply the power for tripping a VCB.



Ratings	Specification	
	Type CB-T1	CB-T2
Rated input voltage	AC100/110V	AC200/220V
Frequency (Hz)	50/60	50/60
Charging volt(V)	140/155	280/310
Charging time	Within 10 Sec. after the AC power off	
Tripping time	Within 30 Sec. after the AC power off	
Allowable Input voltage range	85% ~ 100%	85% ~ 110%
Capacitor rating( $\mu$ F)	1000	560

#### • Dimension

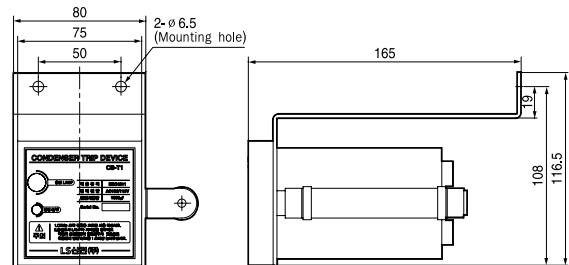

#### • Connection diagram

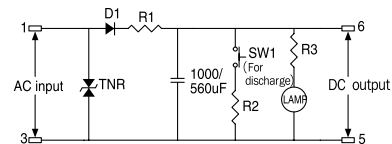

#### • CDT

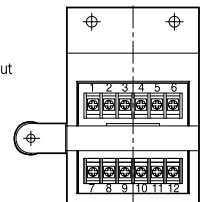

### Rectifier

When the DC power is not available, rectify the AC power and get the DC power for closing coil.

Type	AC Input voltage	Output current	Rating time
VCB-X	1 $\phi$ 100/110V 1 $\phi$ 200/220V	40A DC	10 sec.

#### • Dimension

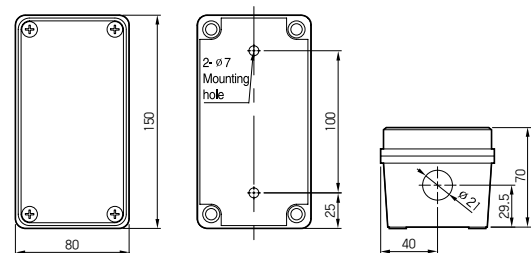

#### • Connection diagram

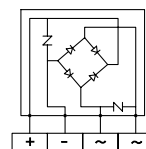

## Standard tool



E, F class



G class



### Handle for draw-in and out

Handle for draw-in and out the VCB  
(Standard feature in the draw-out type)

### Manual charging handle

Handle for charging the spring manually.  
(Standard feature)

# Vacuum Circuit Breaker

## Types and ordering information

### 12kV

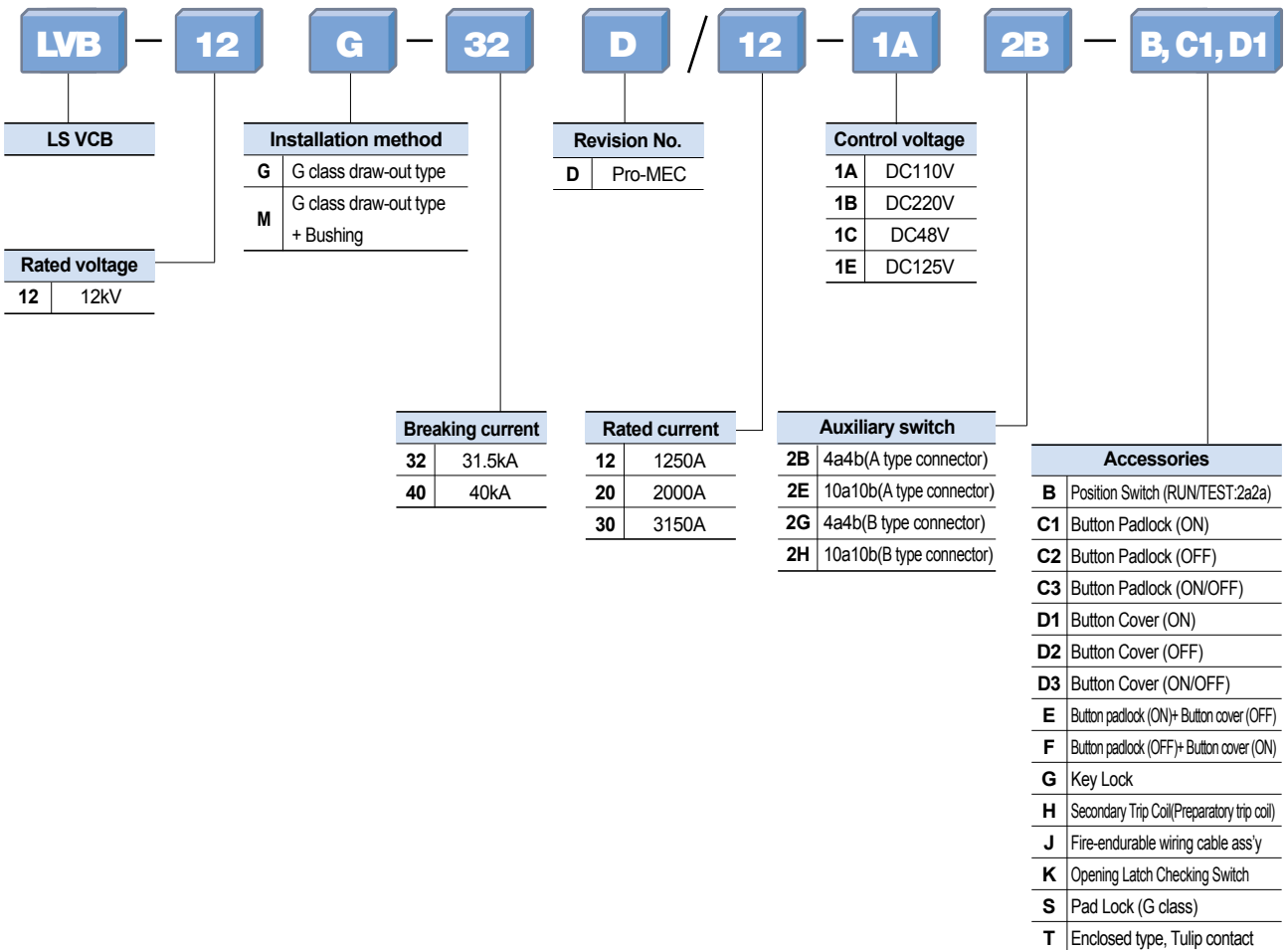

### Cradle

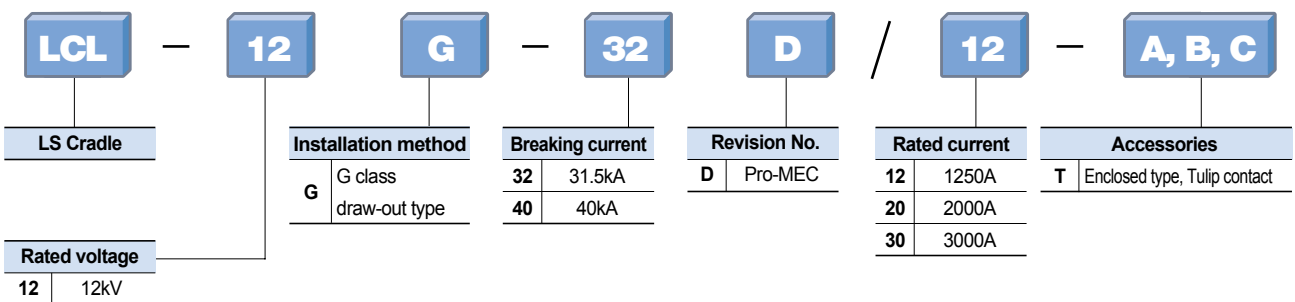

## 17.5kV

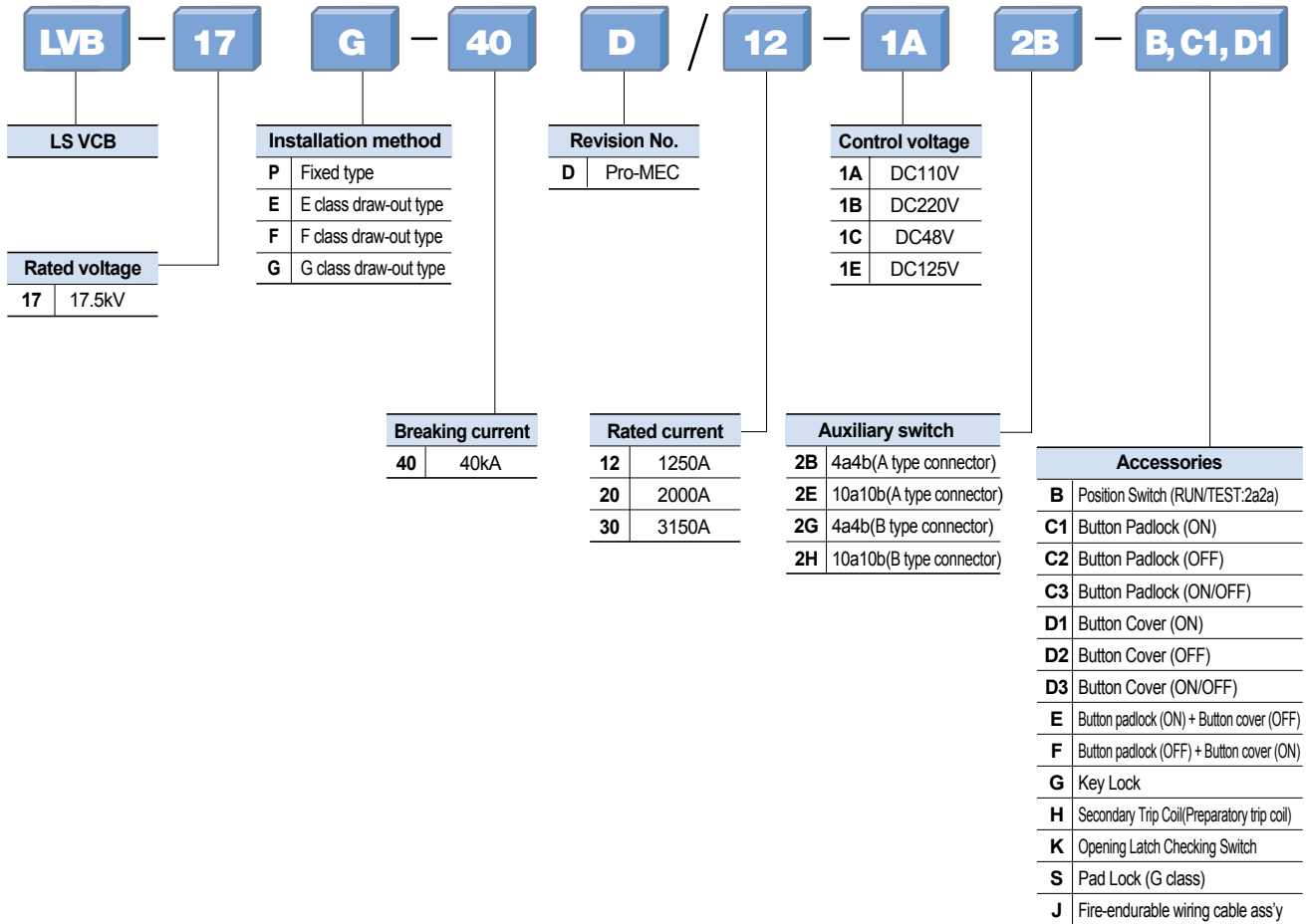

## Cradle

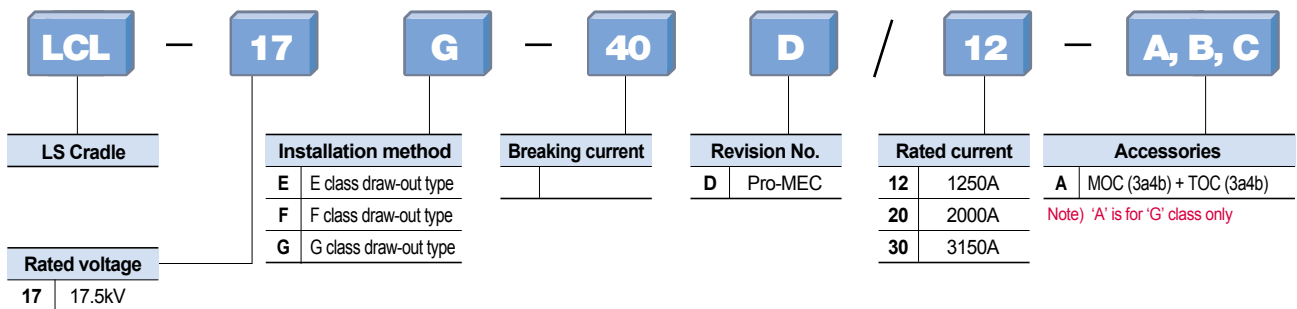

# Vacuum Circuit Breaker

## Types and ordering information

### 24kV

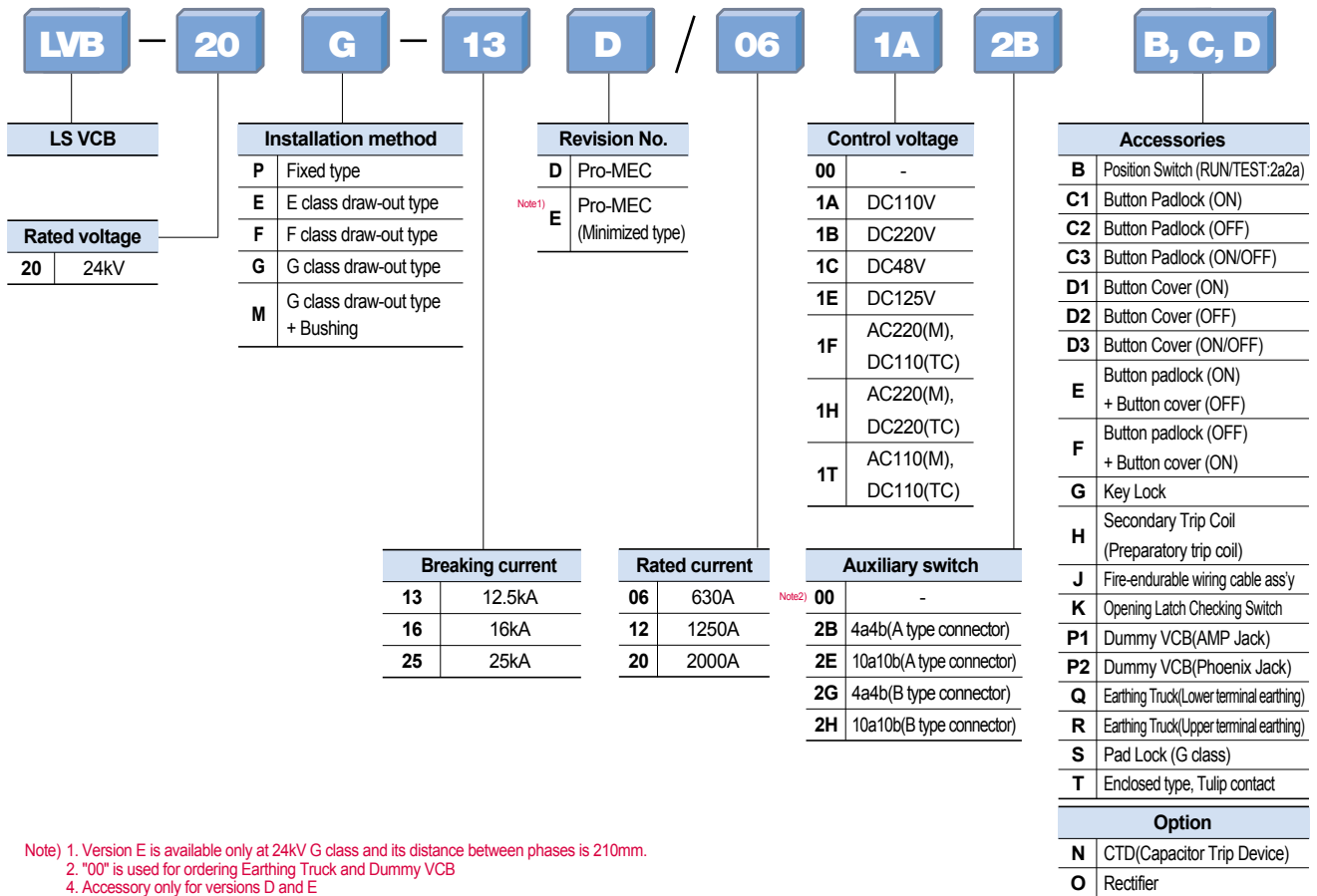

### Cradle

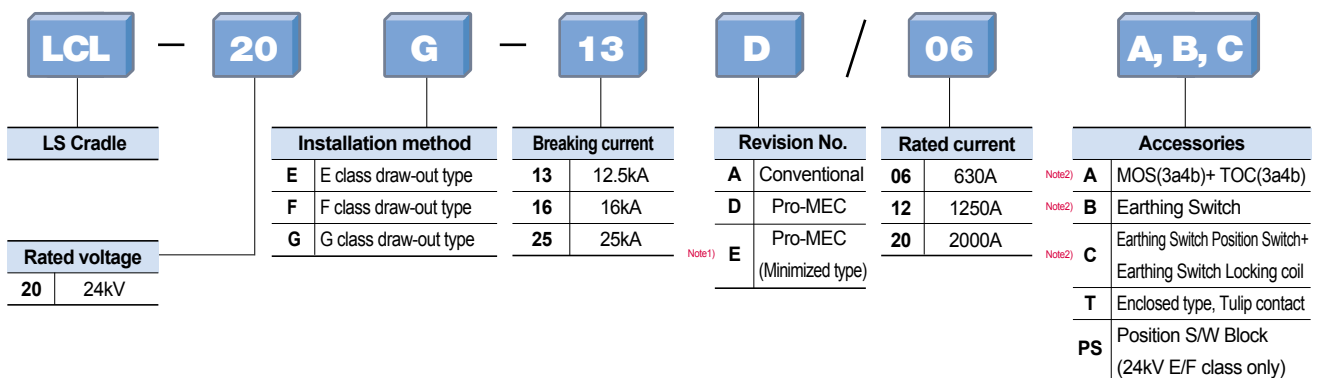

### Features

**Accumulation of more than 20 years of vacuum-related technologies**

**Simplified arc extinguishing system**

Spiral contact structure with Radial magnetic field provides effective dispersing of the arc energy.

**Simple structure and high quality**

Sealing after complete removal of gas in the vacuum chamber in order to secure a long vacuum confidentiality

**Small size and light weight**

The new contact material used to enhance the competitiveness of the size

**Wide rated coverages**

Wide interrupting range from 6kV up to 40.5kV 40kA

**High reliability and electrical life**

Certification by KERI and KEMA according to the latest standard IEC62271-100 (2008) E2, LIST3, M2



### Modeling system

**LV7**

Basic type	
L	LS
V	Vacuum
7	Series No.

**A**

Revision No
A, B...

**-**

**P**

ETC.	
Null	Straight type
P	Potting type
C	Wave type
E	Embedded type
G	Gas Insulation type

# Vacuum Interrupter

## VI internal structure

Largely movable and fixed electrodes and main shield compose the Susol VI. The main components are shown in the following.

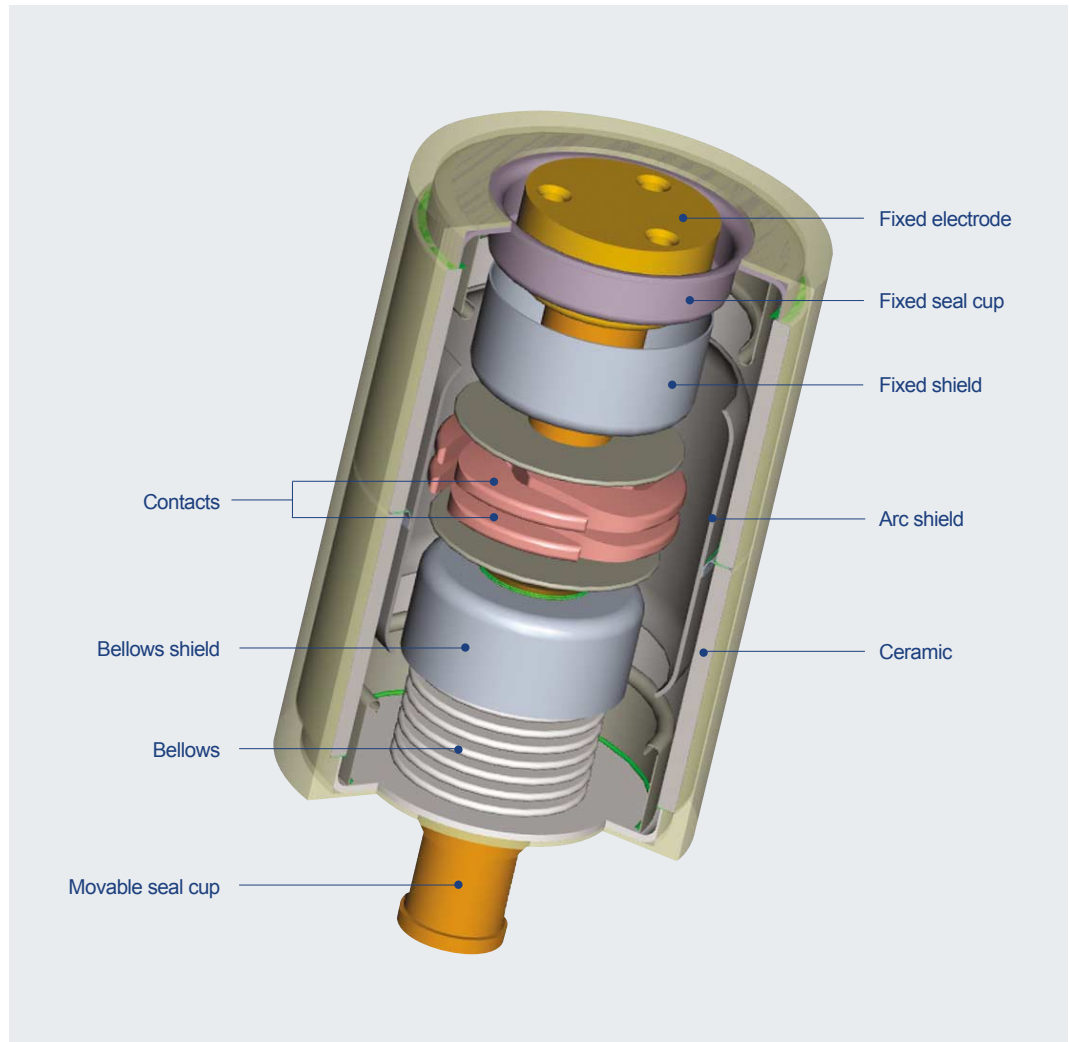

The vacuum rate within the VI is very high (approximately  $5 \times 10^{-5}$  Torr) and the spacing between fixed contact and movable contact is about 6 ~ 20mm, depending on the voltage. The contacts are in a structure that arc can easily be extinguished and the surfaces of the contacts are made of special alloy (copper - chromium) and the interior is completely sealed to prevent loss of vacuum. Therefore the wearing of the contacts can be minimized in the event of short-circuit and the arc energy by overvoltage or switching can be reduced effectively.

## Interrupting action by VI

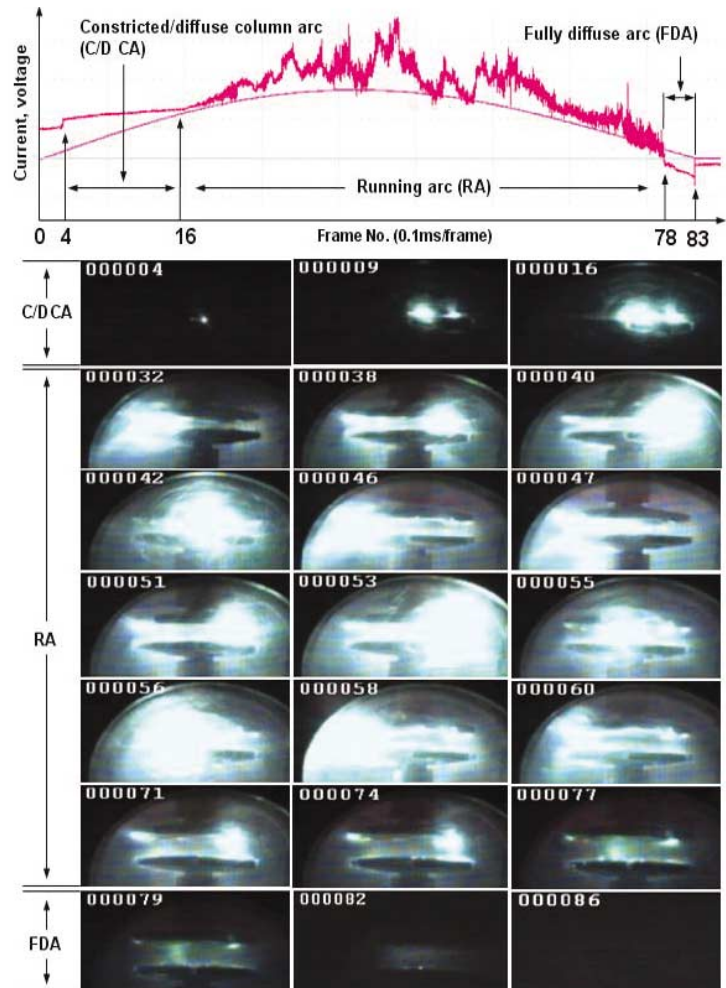

Arc voltage waveforms and arc image captured during arcing time

In case of using the flat contact any of the designs do not reflect on when contacts are opening the arc with high temperature is contracted and fixed in the center of the contacts, Which is called pinch effect. To prevent the effect two kinds of contact shapes are designed. One is Axial magnetic field which spreads the arc before its contraction, and the other is Radial magnetic field which permits the contraction of the arc but makes it rotated to disperse the energy. Because contracted arc is shaped like a cylinder it is called Contracted arc or columnar arc.

Spiral contact structure (Radial magnetic field), using the force ( $F = j \times B$ ) generated by the interaction of the radial magnetic field caused by the current flowing through the arc between two contacts, disperse the arc energy evenly on the surface of contact by rotating the arc that is contracted by the pinch effect so as to minimize contact damage.

The images show arc behavior during the arcing time of about 8ms by shooting with high-speed camera capable of shooting 10,000 frames per sec.

(0.1ms/frame) by focusing on parts of the arcing time on the above graph and simultaneously measured arc voltage also represented to show arc state by section

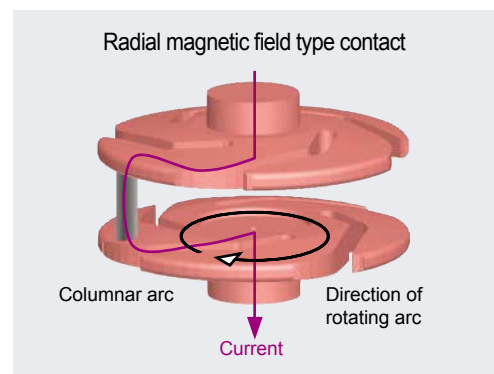

Arc driving principle in the contacts of Radial magnetic field

# Vacuum Interrupter

## VI endurance by interrupting current

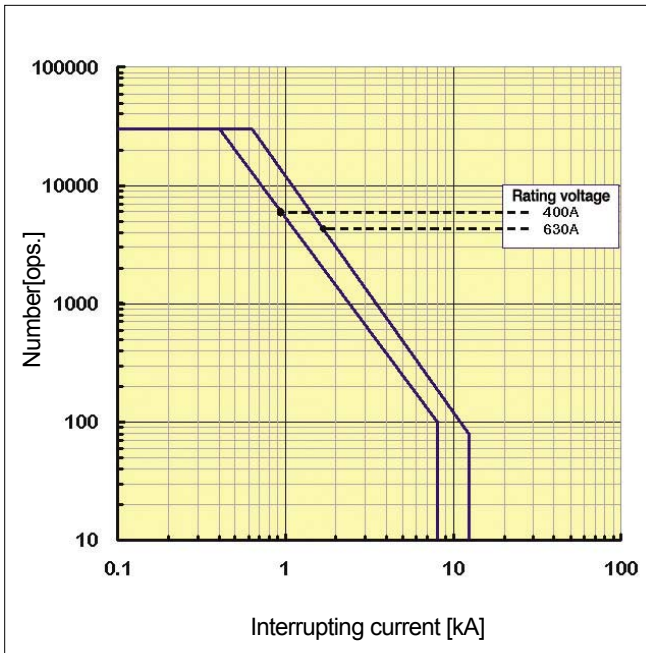

**VI model LV2 at 7.2kV**

- N : Operation numbers
- I : Interrupting current

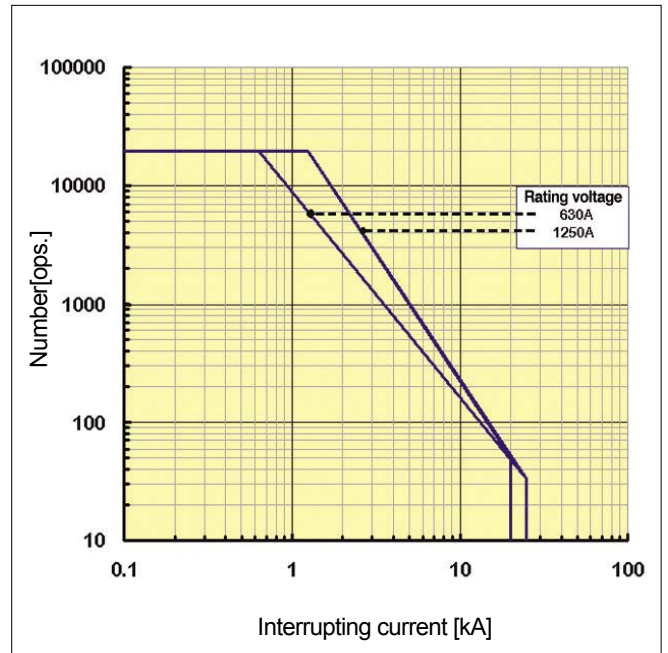

**VI model LV3 at 7.2kV**

- N : Operation numbers
- I : Interrupting current

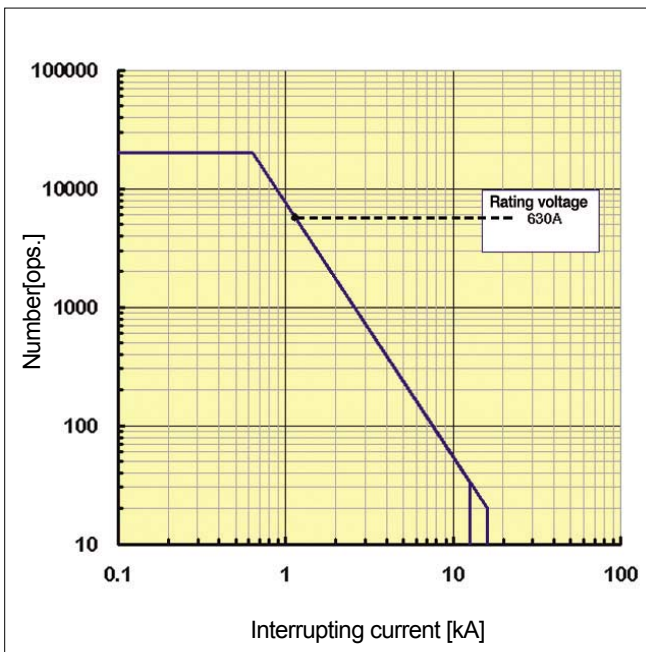

**VI model LV4 at 24kV**

- N : Operation numbers
- I : Interrupting current

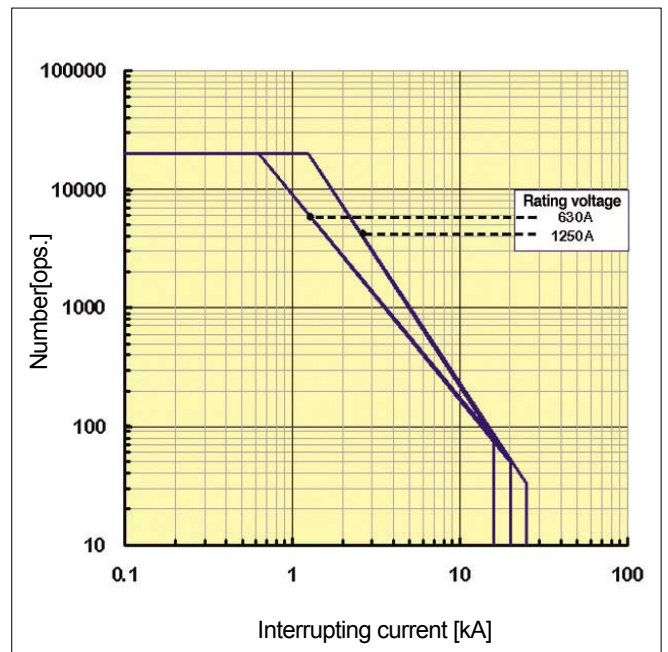

**VI model LV5 at 17.5kV**

- N : Operation numbers
- I : Interrupting current



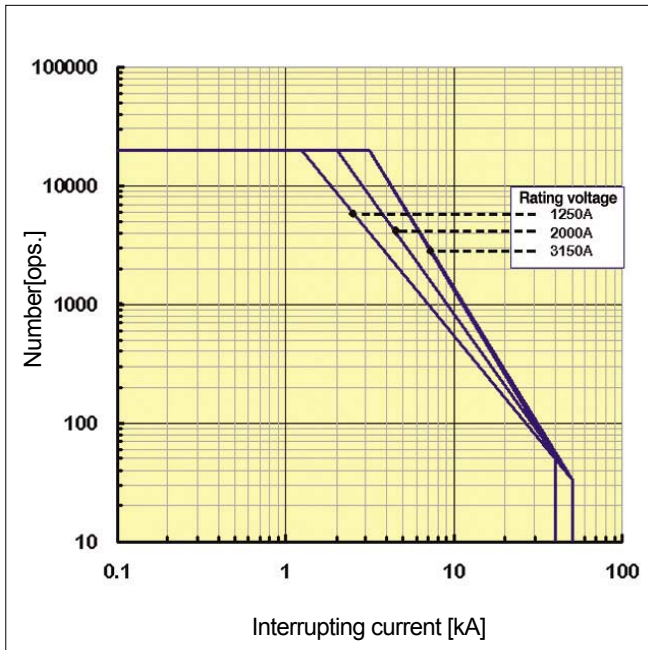

**VI model LV8 at 17.5kV**

- N : Operation numbers
- I : Interrupting current

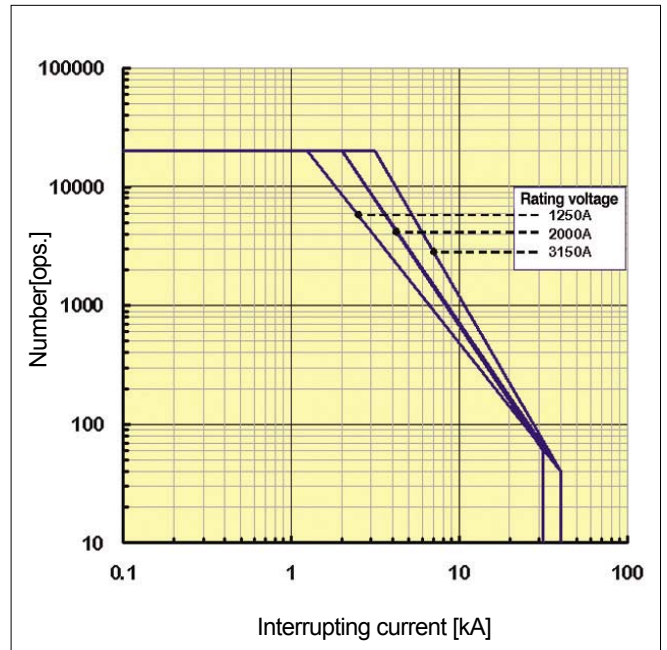

**VI model LV7-P1 at 24kV**

- N : Operation numbers
- I : Interrupting current

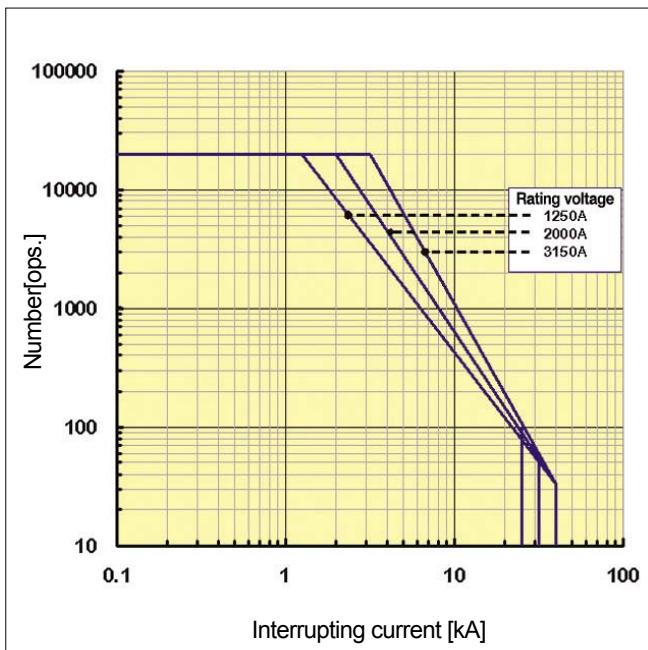

**VI model LV8 at 36kV**

- N : Operation numbers
- I : Interrupting current

Note) 1. Above graphs represent the characteristics of the electrical life of LS Susol VCB.  
 2. Life characteristics of each model in each rating represents the LOG-LOG graphs.

# Vacuum Interrupter

## Dimensions

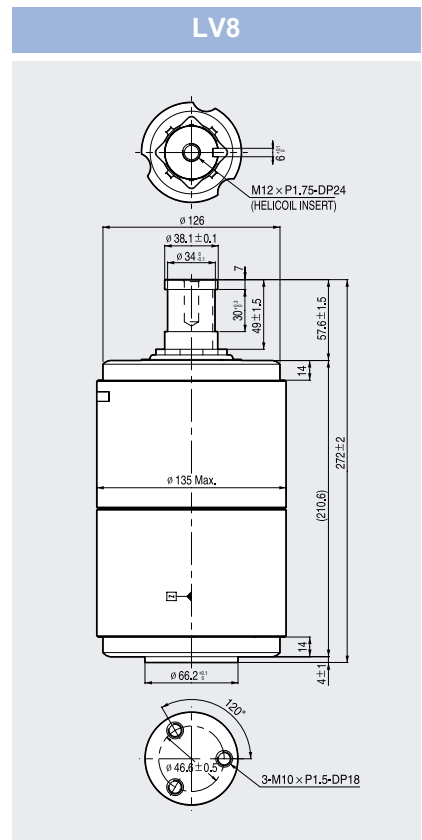
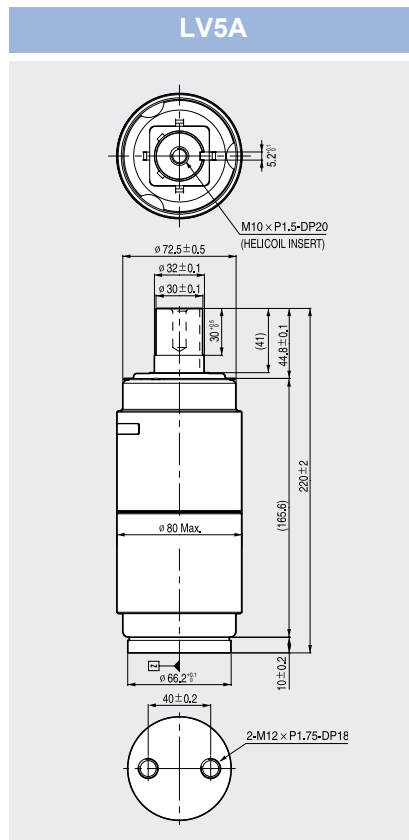
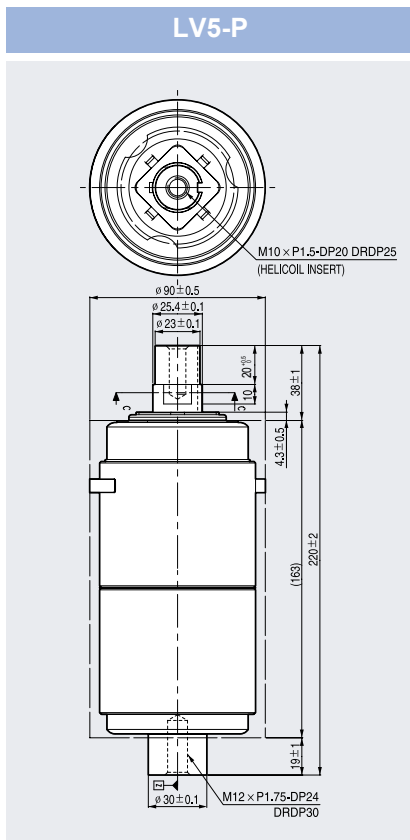
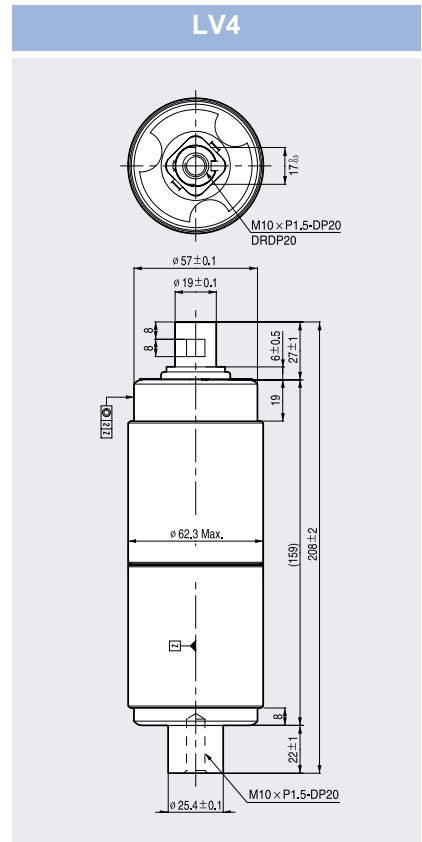
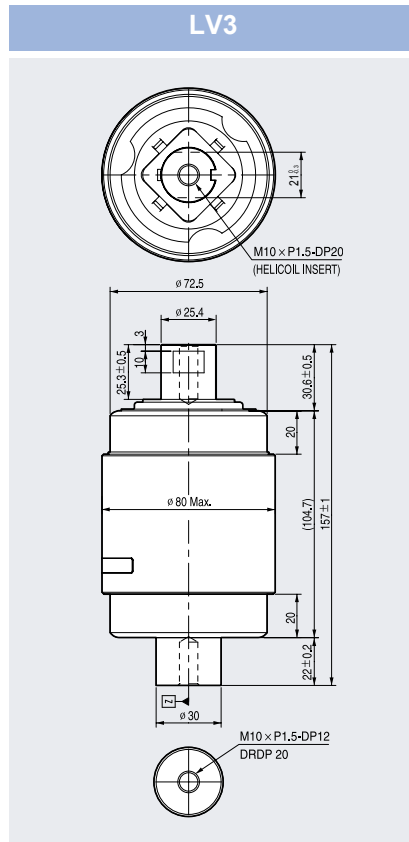
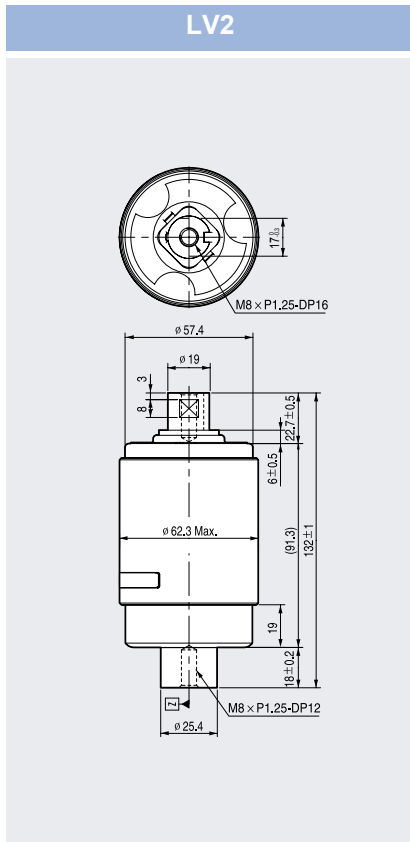

LV7-P1 / LV8-P

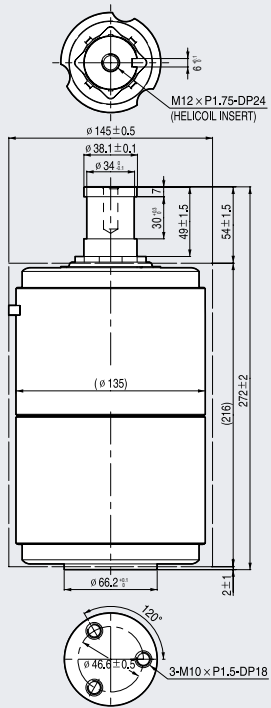

LV7-C

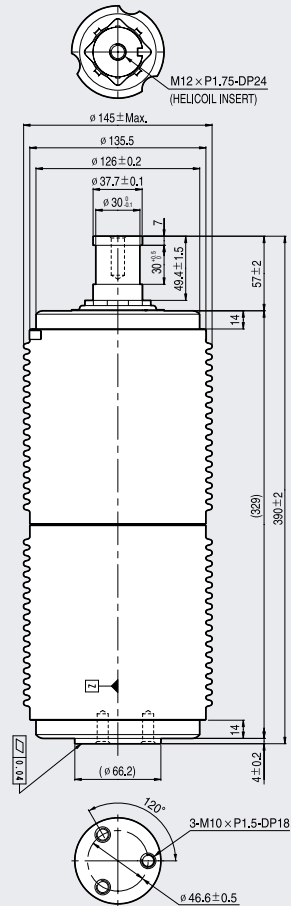



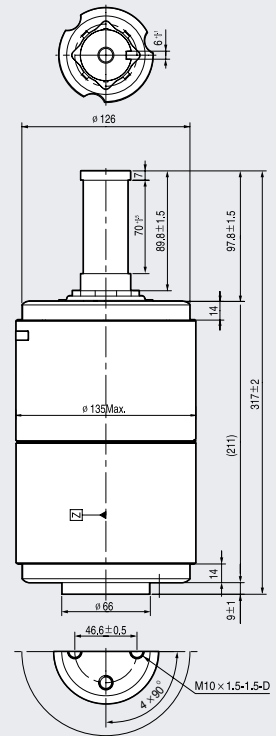

LV10404



# Vacuum Interrupter

## Technical data

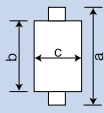
Type		LV2	LV3	LV4-E	LV5-P		
Outer view							
Electrical ratings	Rated voltage (kV)	7.2 7.2		24/25.8	12/17.5		
	Rated power frequency withstand voltage (kV, rms)	20 20		50	42		
	Rated impulse withstand voltage (kV, crest)	60 60		135	95		
	Rated frequency (Hz)	50/60 50/60		50/60	50/60		
	Rated normal current (Amp)	400/630 630/1250		630	630/1250		
	Rated short circuit current (Sym.) (kA)	8	12.5 20	25	20	25	
	Rated short circuit making current (kA, peak)	20.8	32.5	52	65 41.6	52	65
	Rated duration of short-circuit (sec)	3 3		3	3		
Mechanical data	Interrupter weight (kg)	0.8	1.4 1.2	0.5	2.4		
	Moving part weight (kg)	0.3 0.7		0.5	0.7		
	Outline dimension (mm)		a	132 158	208	220	
			b	91 105	159	163	
c			62 80	62	90		
Mechanical requirements	Contact stroke (mm)	6 ± 1 10		± 1	10 ± 1		
	Opening speed, average 0 to 75% of full stroke (m/s)	0.7~1.0		0.7~1.0	1.3~1.5	0.7~1.0	
	Overtravel during opening, Max. (mm)	2 2		2	2		
	Closing speed, average last 33% of full stroke (m/s)	0.7~1.0		0.7~1.0	0.7~1.0		
	Contact bounce duration, Max. (sec)	2 2		2	2		
	Added force from atmospheric pressure (kg · f)	80 154		227	120	154	227
	Contact force from atmospheric pressure (kg · f)	8.5 12.6			9	12.6	
	Contact erosion limit (mm)	3 3			3	3	
	Mechanical life (× 10 <sup>4</sup> , Operations)	M2 M2			M2	M2	

LV5A		LV7-P1			LV7-C		LV8		LV8-P			LV10404		
12/17.5 24/25.8					40.5 17.5				36			7.2/12		25.8
42 65					95 38				70			20/28		70
95 125					185 95				170			60/75		150
50/60 50/60					50/60 50/60				50/60			50/60		
2000		2500 ~3150			~3150 ~3150				~3150			4000		3150
20	25	25	31.5	40	25	31.5	40	50	25	31.5	40	40	50	40
52	65	65	81.9	104	65	81.9	104	130	65	81.9	104	104	130	104
3 4					4 4				4			4		3
3.0		7.3			9.8 6.6				7.3			8.7		
1.0		2.2			2.6 2.2				2.2			2.0		
220 272					390 272				272			317		
160		216			329 210				216			210		
80		145			145 135				145			135		
10±1 12		±1			17~19 12		±1 17~19					10±1 17		±1
0.7~1.0		1.0~1.3			1.3~1.5 1.0~1.3				1.3~1.5			1.0~1.3		
2 2					2 2				2			1.5		
0.7~1.0 0.7~1.0					0.7~1.0 0.7~1.0				0.7~1.0			0.7~1.0		
2 2					2 2				2			2		
154	227	227	306	367	227	306	367	460	227	306	367	367	406	367
12.6 25.5					25.1 25.8				25			25.8		
3 3					3 3				3			3		
M2 M2					M2 M2				M2			M2		





# Pro-MEC MCSG VCB

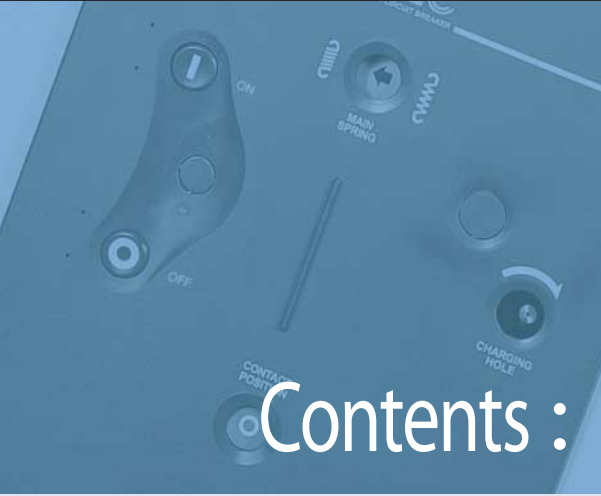

Contents :

# H2

## Vacuum Circuit Breaker for MCSG

Features and Structure

H2-2

Control circuit diagram

H2-4

Dimensions

H2-5



# Vacuum Circuit Breaker for MCSG

## Features and Structure

### Features

- **Module type VCB**

- **Convenient especially for fabricating MCSG**

- Housing is designed like VCB compartment style
- MCSG panel can be easily constructed if combined with Low voltage compartment, Busbar compartment and Cable compartment.

- **Convenient for maintenance and offering high safety**

- Earthing switch can be operated from outside of the panel, and which makes earthing of 3 phases at the same time.
- Without opening the compartment panel door, breaker can be drawn in or out electrically or manually

- **Main functions**

- Breaker : draw- in or out electrically or manually
- Compartment : 3-positions

- **Standard**

- IEC 62271-100

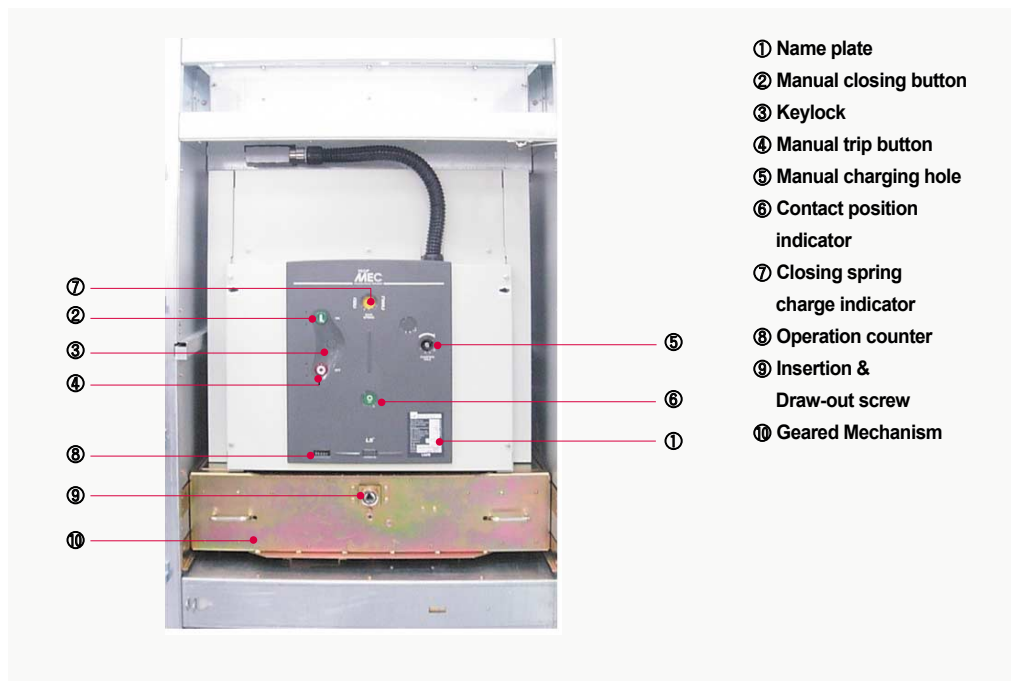

Electrical drive unit

Compartment



Earthing switch



Bushings



Shutter



## Ratings

Type	LVB – 25□-25□/06	LVB – 25□-25□/20
Rated voltage (kV)		25.8
Rated normal current (A)	630 2000	
Rated frequency (Hz)		60
Rated short-circuit breaking current (kA)		25
Rated short-circuit breaking capacity (MVA)		1100
Rated short-time withstand current (kA)		25/3s
Rated short-circuit making current (kA)		65
Rated breaking time (Cycles)		3
Withstand Power frequency voltage Impulse (kV/1.2×50μs)		50/1min
TRV rising rate (kV/μs)		125
TRV max. (kV)		0.47
Rated operating sequence		41
Mechanical lifetime		O-0.3s-CO-3min-CO
Electrical lifetime		10,000operations
Rated control voltage (V)		10,000operations
Rated trip voltage (V)		DC 110V
Standard auxiliary switch		DC 110V
Rated opening time (s)		4a4b, 8a8b
No-load closing time (s)		≤ 0.04
Rated charging motor current (A)		≤ 0.06
Rated closing coil current (A)		≤ 7
Rated trip coil current (A)		≤ 5
Closing spring charging time (s)		≤ 5
Draw-in/out motor voltage (V)		≤ 12
Draw-in/out motor current (A)		DC 110V
Distance between phases (mm)		≤ 5
Weight (kg) breaker compartment	205	236.5
Weight (kg) compartment	281 293	
Installing		G
Applied standard		IEC 62271-100

### • Breaker

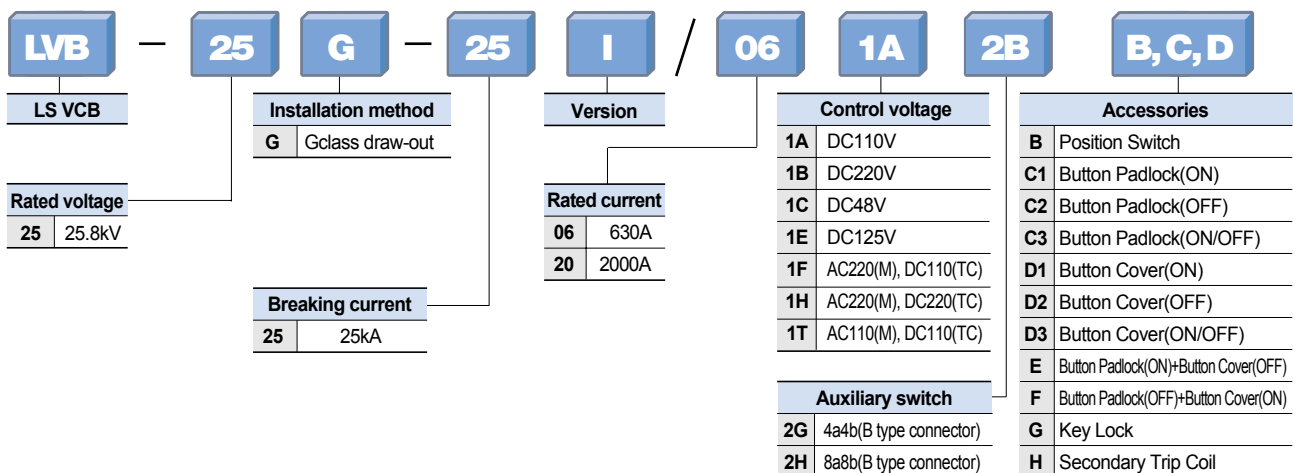

### • Cradle(Compartment)

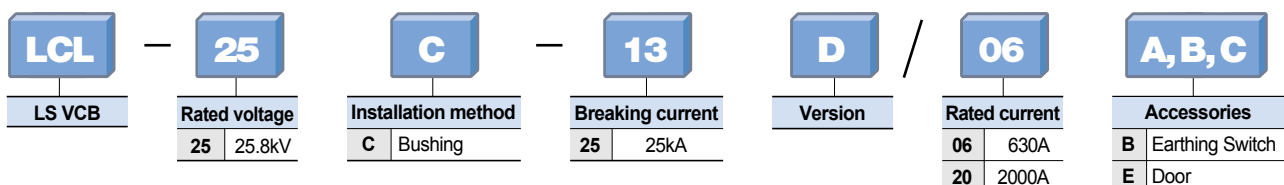

# Vacuum Circuit Breaker for MCSG

## Control circuit diagram

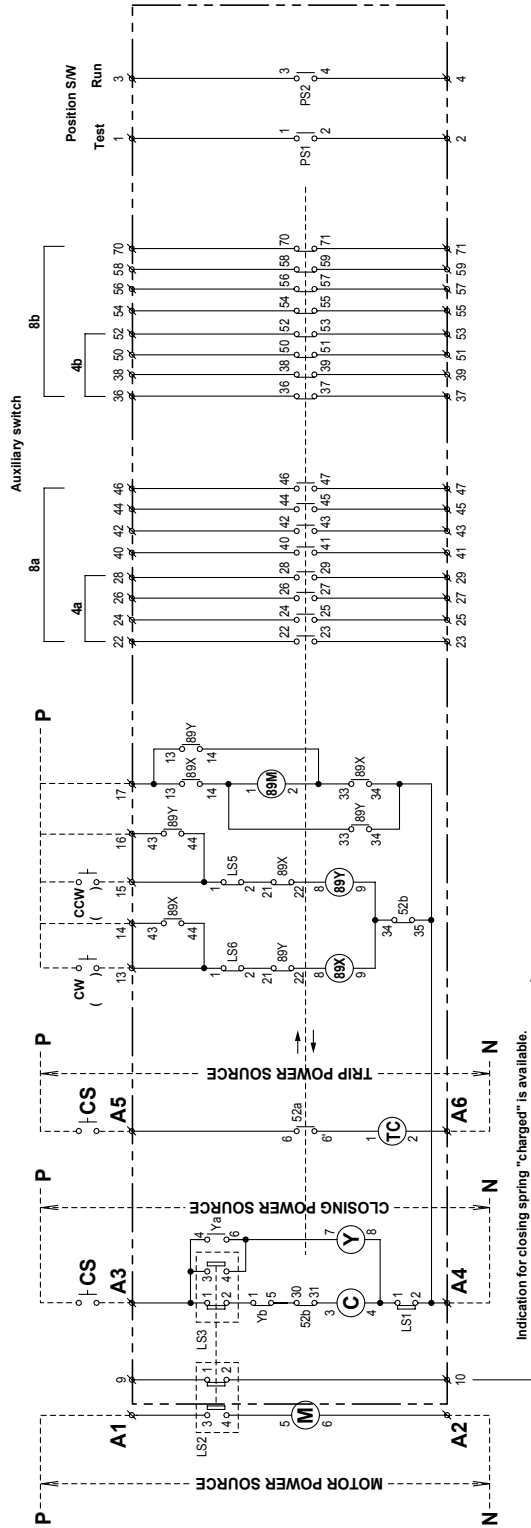

- ∅ : External terminal of VCB
- 52 : Vacuum circuit breaker
- M : Spring charging motor
- TC : Trip coil
- TC1 : Secondary trip coil
- C : Closing coil
- Y : Anti-pump relay
- 52a : Auxiliary switch (NO)
- 52b : Auxiliary switch (NC)
- LS1 : Closing interlock limit switch(only withdrawable type)
- LS2 : Motor stopping, closing spring charged indication
- LS3 : Anti-closing, Anti-pumping limit switch
- LS5 : "Off" at Test Position
- LS6 : "Off" at Run Position
- PS1 : Position SW("On" at Test Position)
- PS2 : Position SW("On" at Run Position)
- 89X : Auxiliary Relay for Inserting
- 89Y : Auxiliary Relay for withdrawing
- 89M : Motor for withdrawing and Inserting

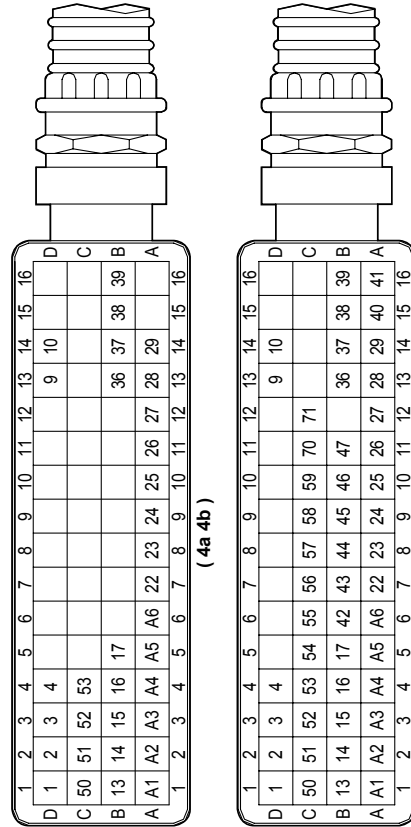

SECONDARY DISCONNECT WIRING  
( TOP VIEW )

## Cradle(Compartment) - w/o Earthing Switch

### • Front

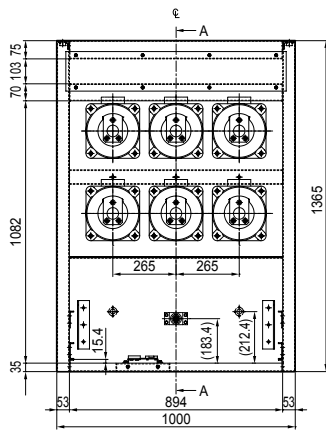

### 〈A-A Section View〉

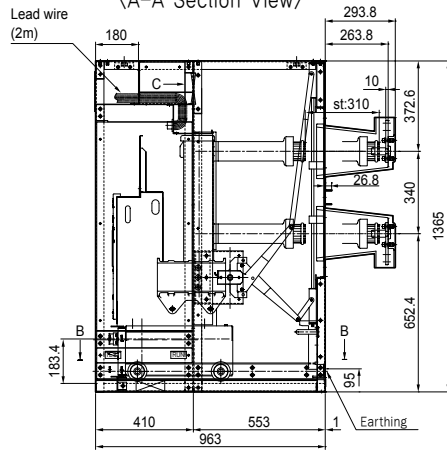

### • Rear

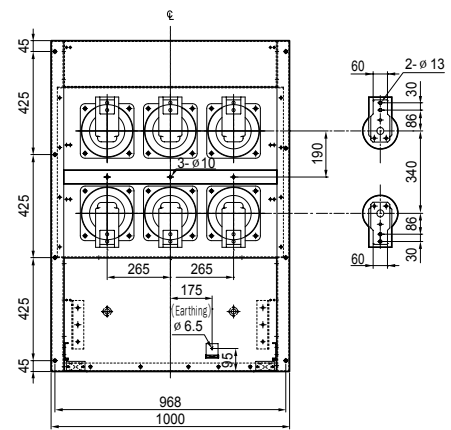

### • Top

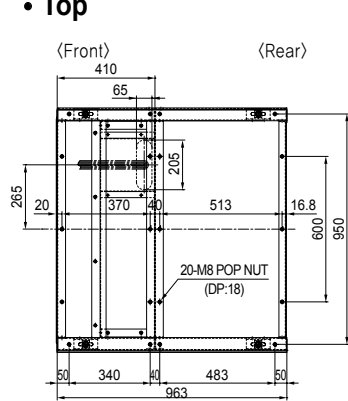

### 〈B-B Section View〉

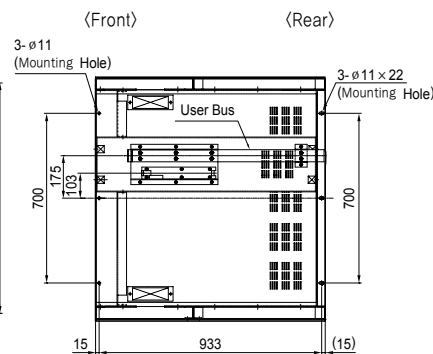

### 〈C-View(Cover 2 Cutting)〉

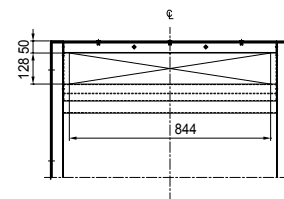

## G type breaker + track(electric draw-in/out)

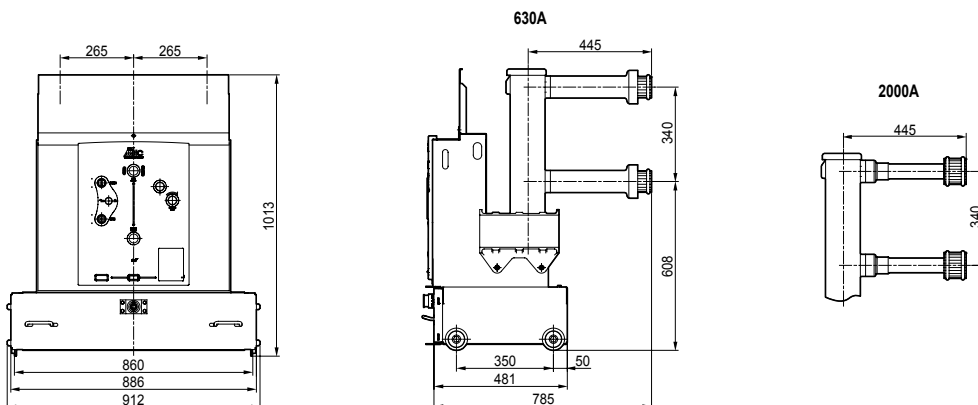

# Vacuum Circuit Breaker for MCSG

## Dimensions

### Cradle(Compartment) - w/ Earthing Switch

• Front

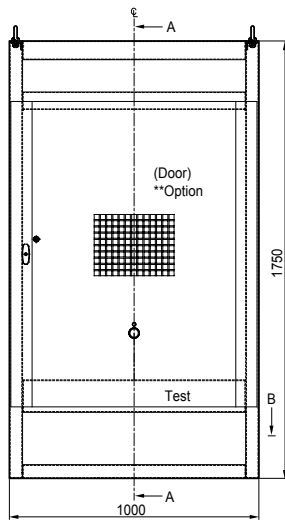

• Side

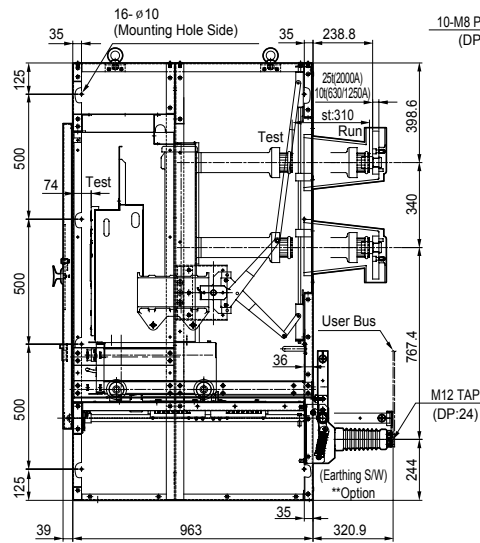

• Rear

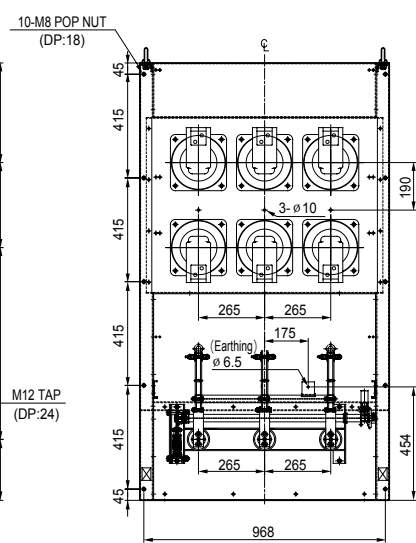

• Top

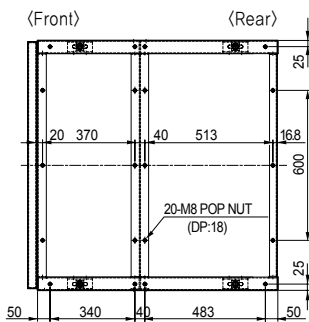

<B-B Section View>

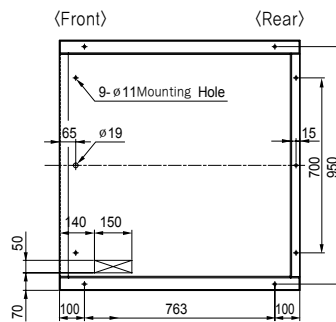

<Terminal conductor>

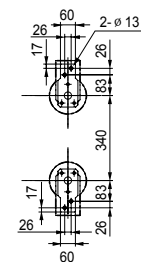



# Power Plants VCB

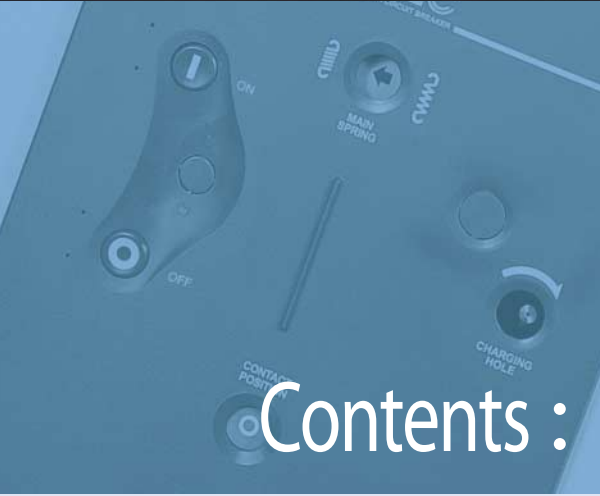

Contents :

# H3

## Vacuum Circuit Breaker for Power Plants

Ratings	H3-4
Ratings of Accessories	H3-5
Accessories	H3-6
Control circuit diagram	H3-8
Dimensions	H3-9
Types and ordering information	H3-14



# Vacuum Circuit Breaker



## Power Plants

A product developed for water and thermal power plants due to the revision and application of Kepco's standard (ES150) followed by the IEC standard revision. It has completed the high capacity (40~50kA) VCB series for power plants by securing higher breaking capacity, safety and reliability.



### VCB Full Option

To prevent fatal error, property and life loss caused from operator during operation, it is equipped with safety mechanisms such as shutter padlock.

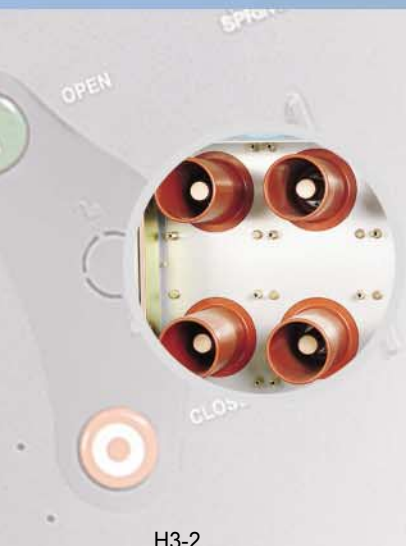

### Bushing applied for Window CT adaptation

The bushing provides sufficient strength to collaborate with the internal insulation and is adaptable with CT offering safety mechanically and electrically when applying large current.

# WCB

## Vacuum Circuit Breakers



It is recognized for reliability by acquiring new IEC 62271-100 and ES150 (KEPCO standard specification on AC breakers)

# Vacuum Circuit Breaker for Power Plants

## Ratings

Type	LVB-06G-40H			LVB-06G-40J				LVB-06G-50J			
Rated voltage (kV)	7.2										
Rated normal current (A)	1200	2000	3000	1250	2000	2500	3150	1250	2000	3150	
Rated frequency (Hz)	60										
Rated short-circuit breaking current (kA)	40							50			
Rated short-circuit breaking capacity (MVA)	500							624			
Rated short-time withstand current (kA/3sec)	40							50			
Rated short-circuit making current (kAp)	104							130			
Rated breaking time (Cycle)	3										
Rated opening time (sec)	≤ 0.04										
No-load closing time (sec)	≤ 0.06										
Withstand Power frequency (kV/min)	20										
voltage Impulse (kV/1.2 × 50μs)	60										
Rated operating sequence	CO-15s-CO			O-0.3s-CO-3min-CO							
Rated charging motor current (A)	5 (at DC125V)							5 (at DC110V)			
Rated closing coil current (A)	3 (at DC125V)							3 (at DC110V)			
Rated shunt coil current (A)	3 (at DC125V)							3 (at DC110V)			
Type Mechanical	M2										
test Electrical	E2 (Maintenance free)			E2 (List1)							
Capacitive current switching	C2										
Lifetime Mechanical Without maintenance	10000 operations										
Maintenance	20000 operations										
Electrical Without maintenance	10000 operations										
Maintenance	20000 operations										
Auxiliary switch	3a3b										
Installing Draw-out G-type	Visible, Tulip										
Weight Breaker G-type (kg)	200	260		200	260			200	260		
Cradle G-type (kg)	190	230		190	230			190	230		
Applied standard	ES150 <sup>NOTE)</sup>			IEC 62271-100							
Type test laboratory	KERI										

Note) ES150: KEPCO's standard in which IEC62271-100 is applied  
 KERI: Korea Electrotechnology Research Institute



## Motor

When the closing spring is charged, the control power of motor is turned off by the built-in limit s/w.

Rated voltage	The peak value of the inrush current (A)	Rated current (A)	Consumption power (W)	Charging time (Sec.)
DC 110V	20	3	330	12
DC 125V	20	3	330	12

Note) Range of the normal operating voltage: 85~110% of rated voltage

## Closing Coil (C)

When the rated volt is applied to the coil the breaker is closed. The electrical anti-pumping circuit is built-in it.

Rated voltage	Rated current (A)
DC 110V	3
DC 125V	3

Note) Range of the normal operating voltage: 75~125% of rated voltage

## Shunt coil (TC)

When the rated volt is applied to the coil the breaker is opened.

Rated voltage	Rated current (A)
DC 110V	3
DC 125V	3

Note) Range of the normal operating voltage: 60~125% of rated voltage

## Auxiliary switch

Standard configuration : 3a3b1b of early-b contact function exists inside

Classification		Resistive load (A)	Inductive load (A)	Contact configuration
Contact Ratings	DC	110V 10	5	3a3b
		125V 10	5	

Note) The contact ratings of Mechanical Operated Cell Switch(MOC) are the same with that of the Aux. switch.

Truck Operated Cell Switch(TOC)

Classification		Resistive load (A)	Inductive load (A)	Contact configuration
Contact Ratings	DC	110V 10	5	3a3b
		125V 10	5	

Position of the Auxiliary switch

Breaker a	Switch	Mechanism		MOC		TOC	
		a	b	a	b	a	b
RUN	CLOSE	ON	OFF	ON	OFF	ON	OFF
	OPEN	OFF	ON	OFF	ON	OFF	ON
TEST	CLOSE	ON	OFF	ON *	OFF *	ON	OFF
	OPEN	OFF	ON	OFF *	ON *	OFF	ON

Note) \* applied in the VCB of which MOC is operable at the TEST position.

## Charge indicator of the closing spring

Indicating the condition of the closing spring.



## Position indicator of the main contacts

Indicating the 'Close' or the 'Open' of the main contacts.

Close position: 「ON」 Open position: 「OFF」



## Counter

Mechanically counts the operation of the VCB by 5digits

# Vacuum Circuit Breaker for Power Plants

## Accessories

### Accessories for breakers

- **Position padlock**

It is located at the screw hole to prevent the draw-in and out of a breaker from the present position(Disconnected, Test or Connected)

- **Mechanical position indicator**

It is located in the lower part of a breaker to check the present position - Disconnected, Test or Connected- easily.

- **Position interlock**

The breaker is locked in each position-Disconnected, Test or Connected, thus it is necessary to release the lock before draw-in or out of a breaker from the present position.

- **Auto connection**

When the breaker is moved to Test position from Disconnected position the connector for control powers is automatically connected. In case of reverse moving of the breaker the connector is automatically disconnected.

- **Code plate**

When the breaker is inserted to the cradle, if the ratings does not match with the cradle, it mechanically prevents the breaker from being inserted into the cradle.



## Accessories for breakers

- **Mechanically operated cell switch (MOC)**

It is auxiliary switch (6a6b), which indicates the 'ON' or 'OFF' condition of a VCB, and operated when the VCB is in 'Run' state.

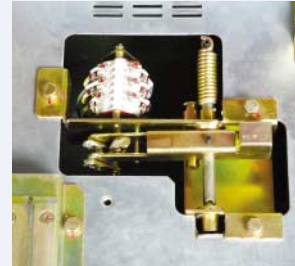

- **Truck operated cell switch (TOC)**

It is auxiliary switch (6a6b), which indicates the 'Run' state of a VCB and is operated by the movement of a VCB frame.

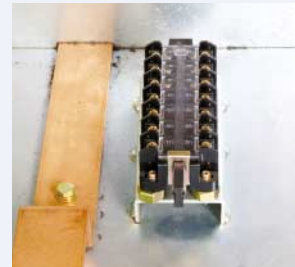

# Vacuum Circuit Breaker for Power Plants

## Control circuit diagram

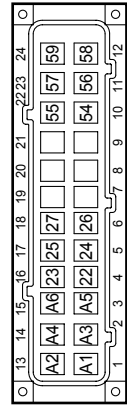
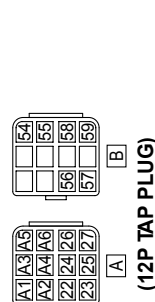
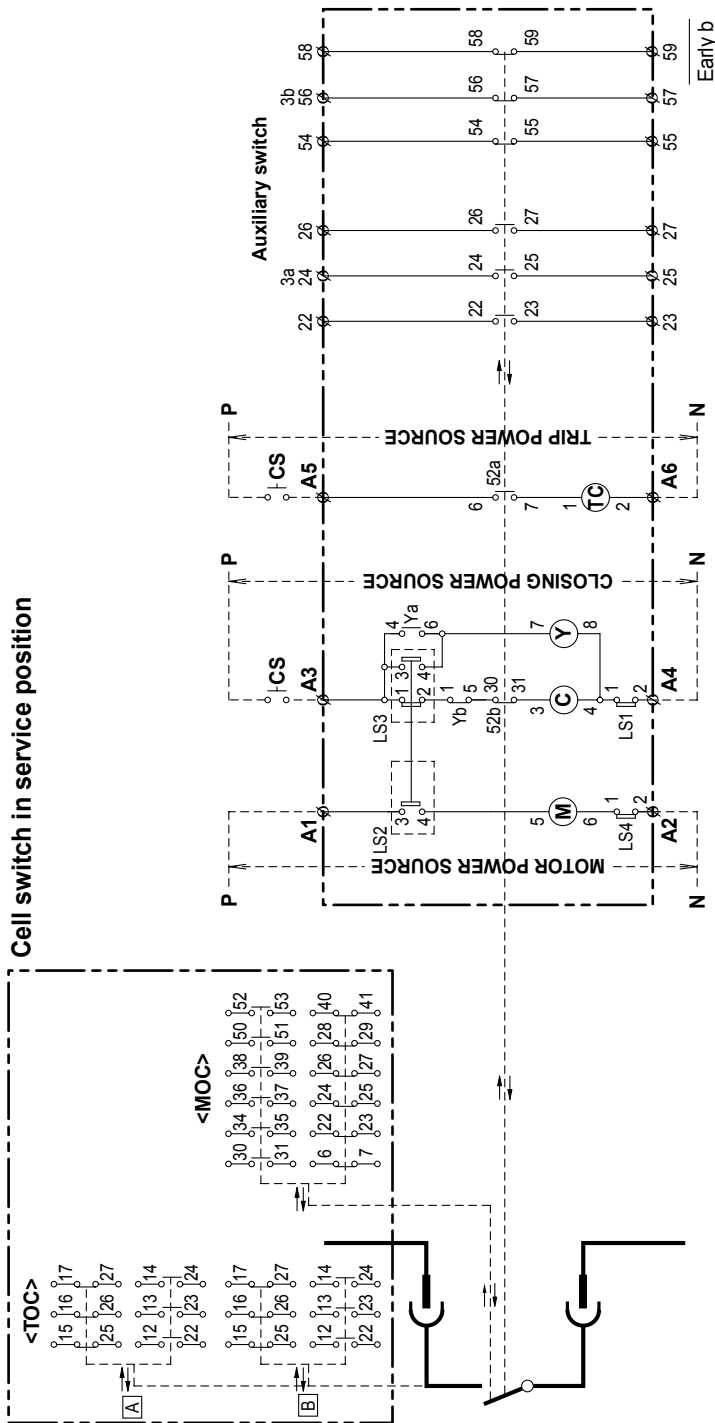

Note) Diagram shows the circuit breaker in position "OFF" with closing spring "Charged"

- ∅ : External terminal of VCB
- 52 : Vacuum circuit breaker
- M : Spring charging motor
- TC : Trip coil
- C : Closing coil
- Y : Anti-pump relay
- 52a : Auxiliary switch (NO)
- 52b : Auxiliary switch (NC)
- LS1 : Closing interlock limit switch
- LS2 : Motor stopping
- LS3 : Anti-closing, Anti-pumping limit switch
- LS4 : Motor Charging interlock limit switch

## LVB-06G-40H, 40J G class (Visible, Tulip contact)-(1200, 1250, 2000A)

(unit : mm)

### • Front

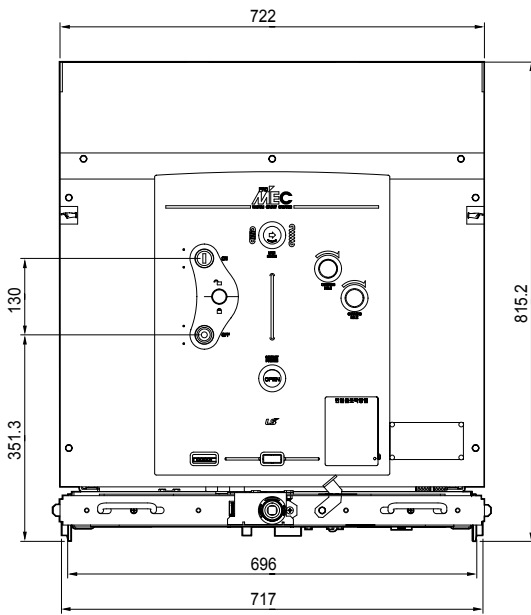

### • Side

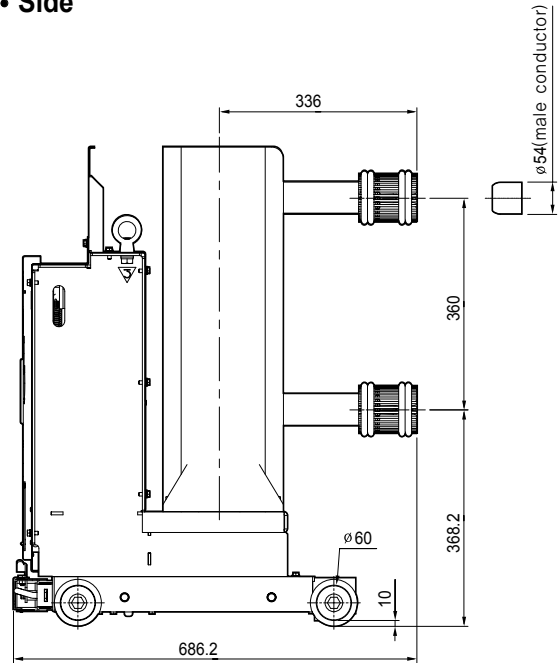

### • Top

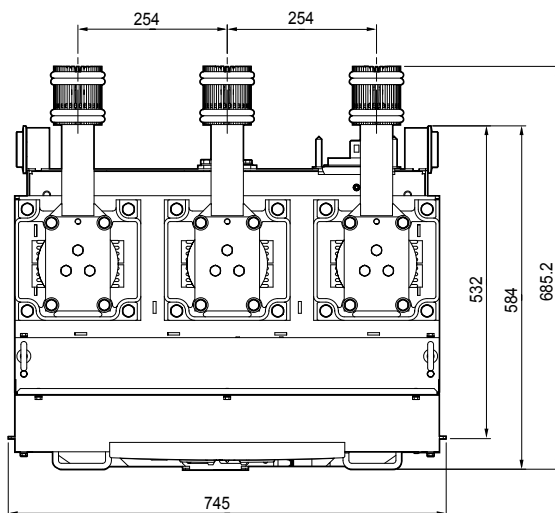

### <Conductor>

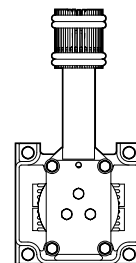

1200/1250/2000A

# Vacuum Circuit Breaker for Power Plants

## Dimensions - Breakers

### LVB-06G-40H, 40J G class (Visible, Tulip contact)-(2500, 3000, 3150A)

(unit : mm)

#### • Front

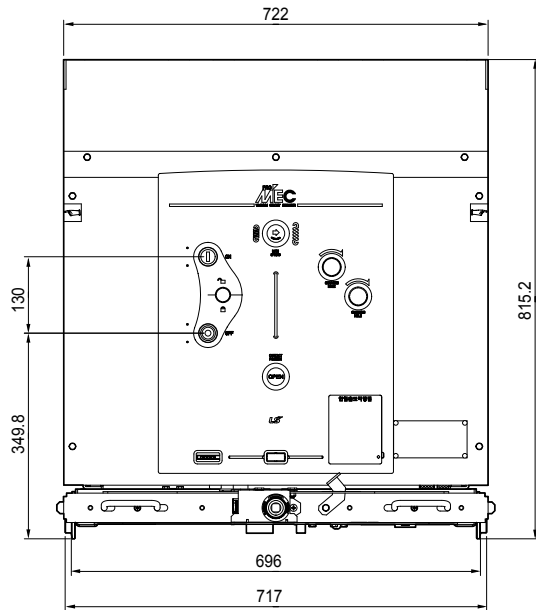

#### • Side

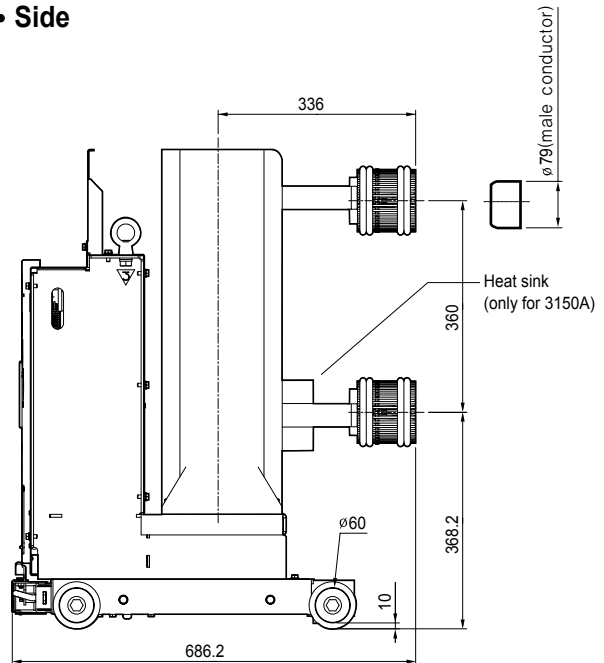

#### • Top

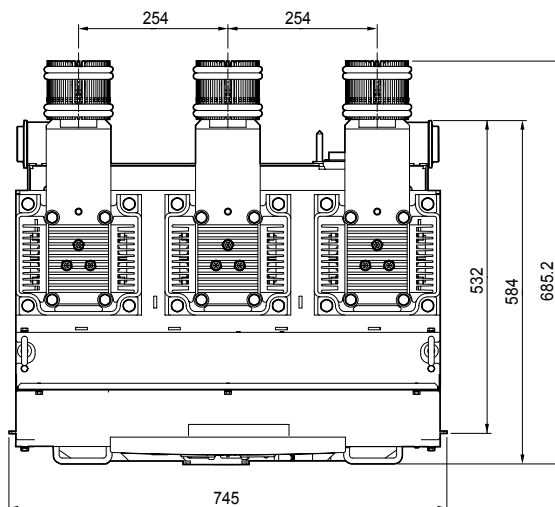

#### <Conductor>

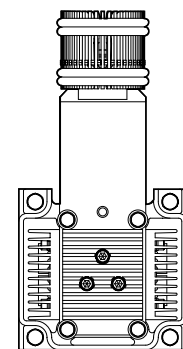

2500/3000/3150A

## LVB-06G-50J G class (Visible, Tulip contact)-(1250, 2000A)

(unit : mm)

### • Front

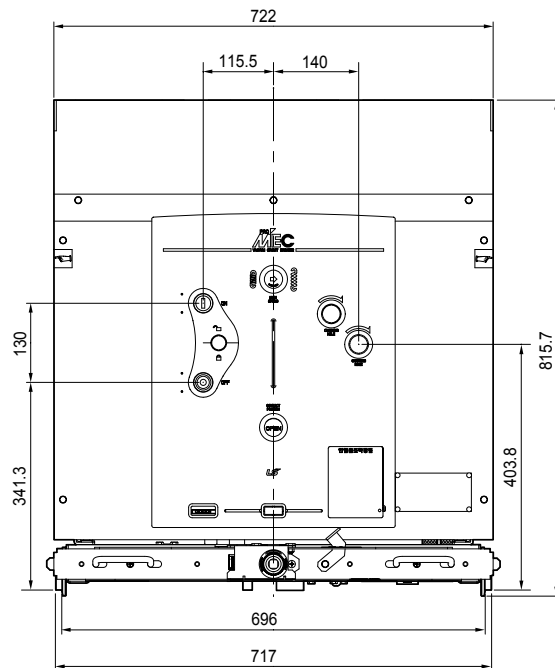

### • Side

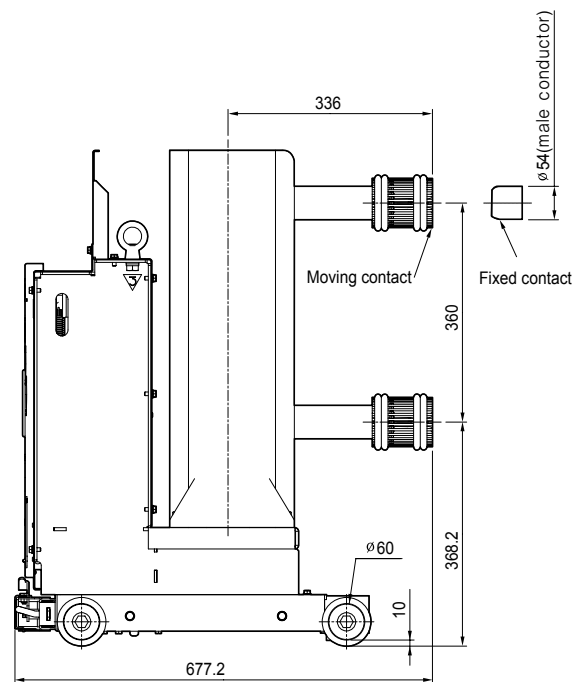

### • Top

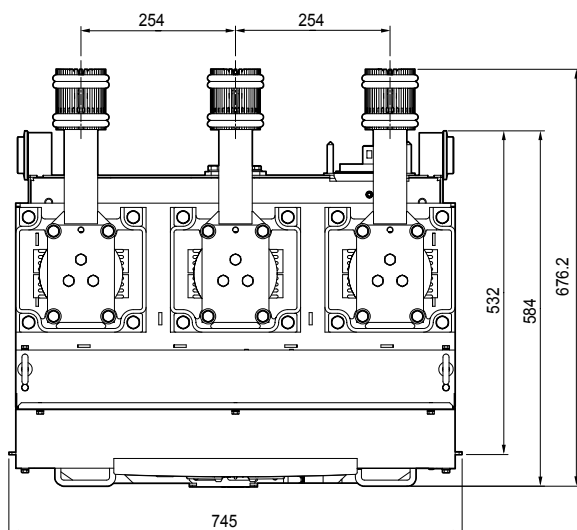

# Vacuum Circuit Breaker for Power Plants

## Dimensions - Breakers

### LVB-06G-50J G class (Visible, Tulip contact)-(3150A)

(unit : mm)

#### • Front

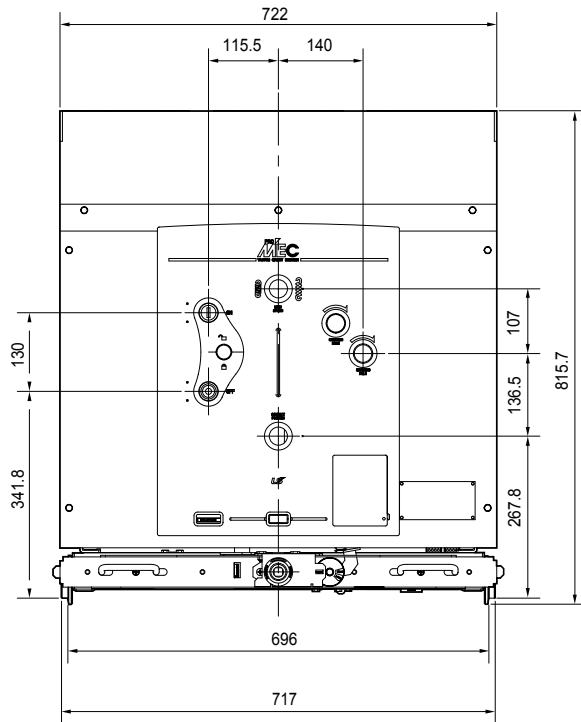

#### • Side

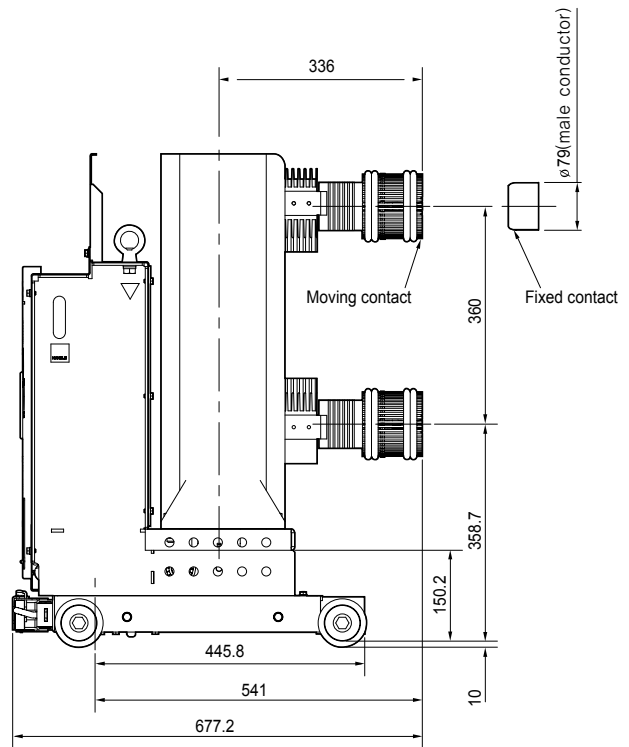

#### • Top

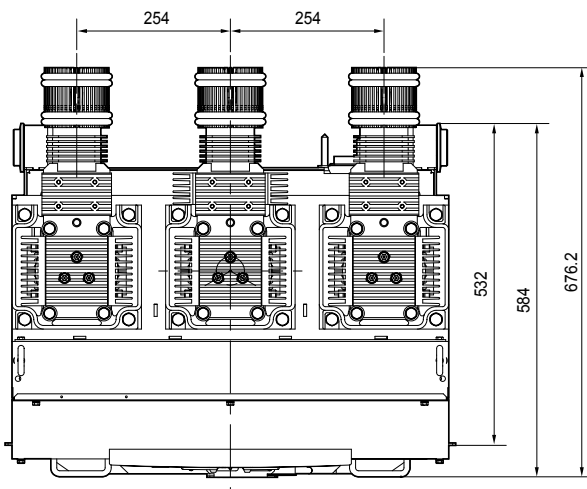



# Cradles

(unit : mm)

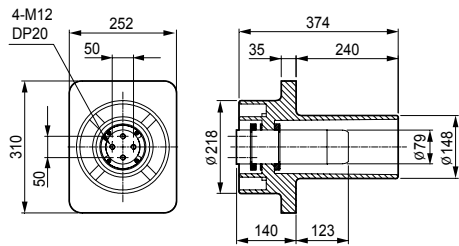

**2500/3000/3150A**

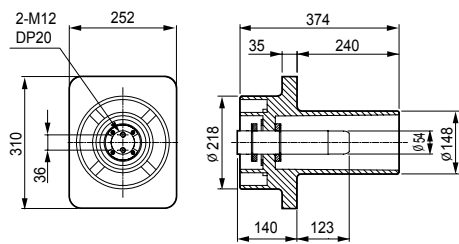

**1200/1250/2000A**

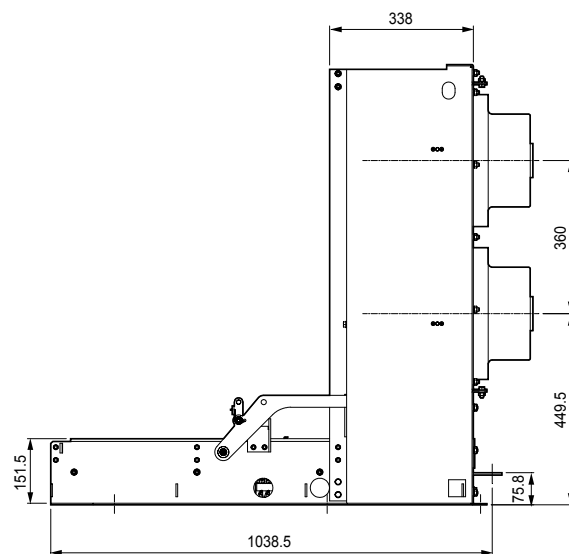
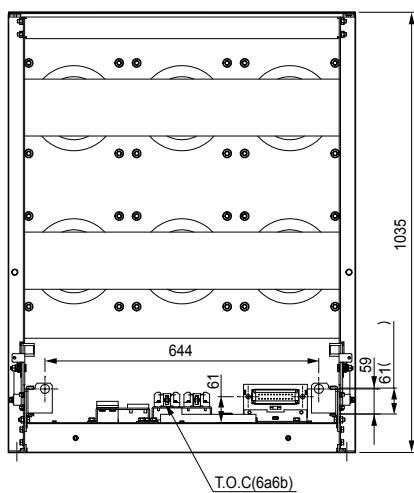
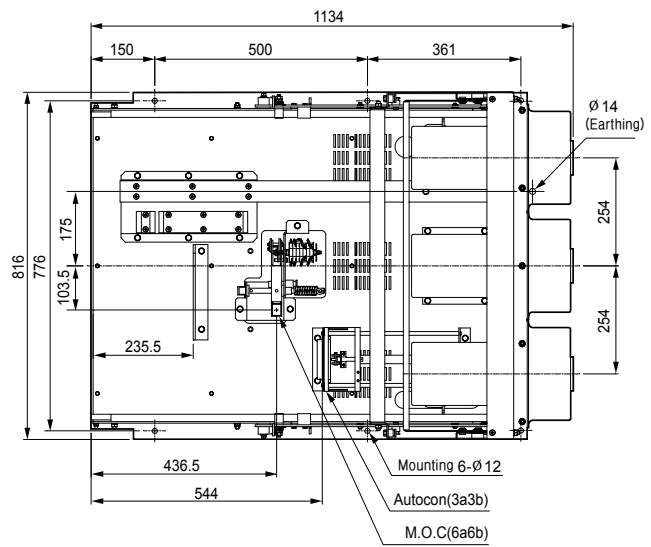

# Vacuum Circuit Breaker for Power Plants

## Types and ordering information

### Breaker

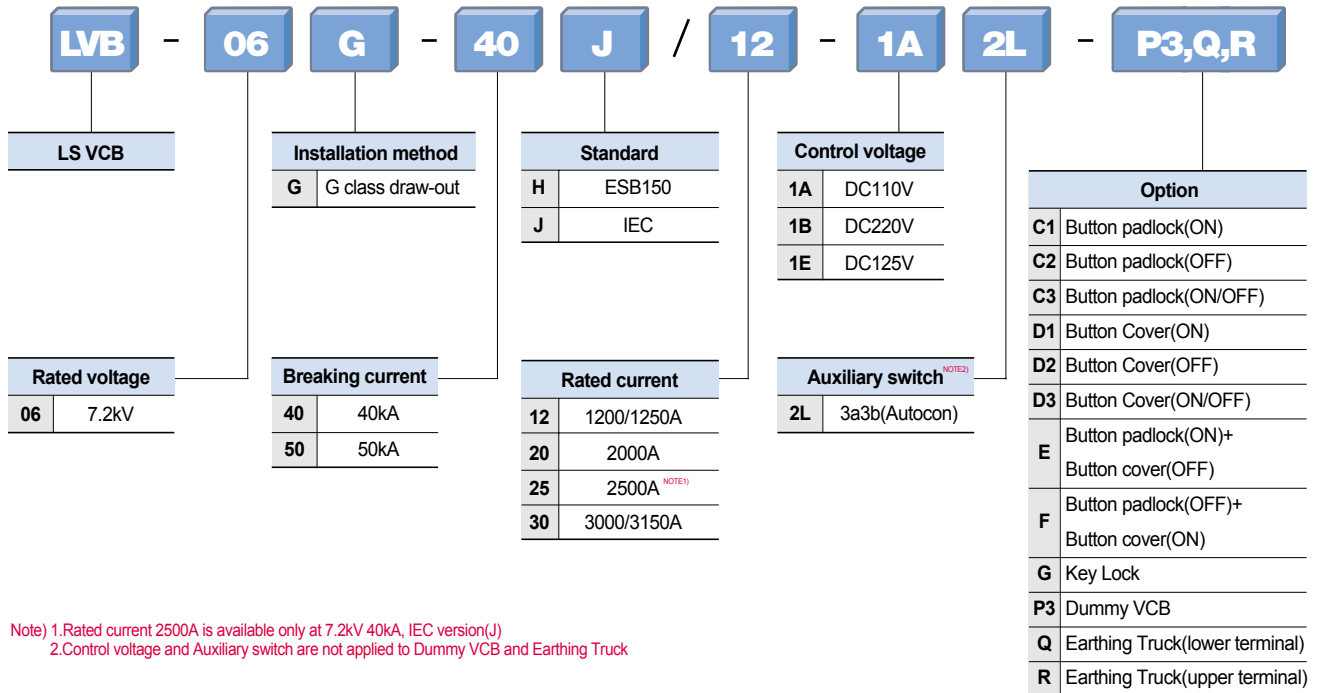

### Cradle

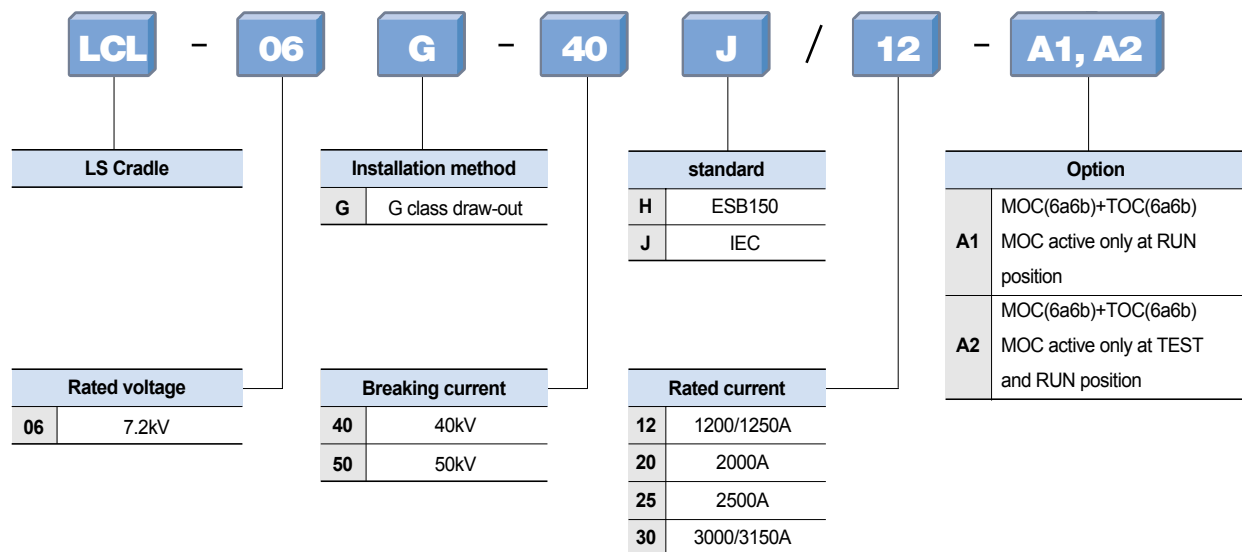



# Nuclear Power Plants VCB

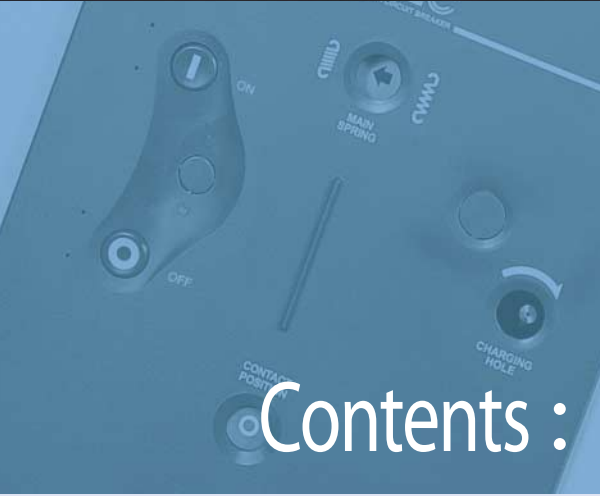

Contents :

# H4

## Vacuum Circuit Breaker for Nuclear Power Plants

Ratings	H4-4
Ratings of Accessories	H4-5
Accessories	H4-6
Control circuit diagram	H4-8
Dimensions	H4-9
Types and ordering information	H4-11



# Vacuum Circuit Breaker



## Nuclear Power Plants

It was developed for KEPCO nuclear power stations. This breaker satisfies quality, safety measures (secure from earthquake and other environments), and surge protection class complies with "1E-CLASS" provisions. It is featured with high breaking technologies, safety, and reliability by applying our own vacuum interrupters (50KA) approved by ANSI standard tests.

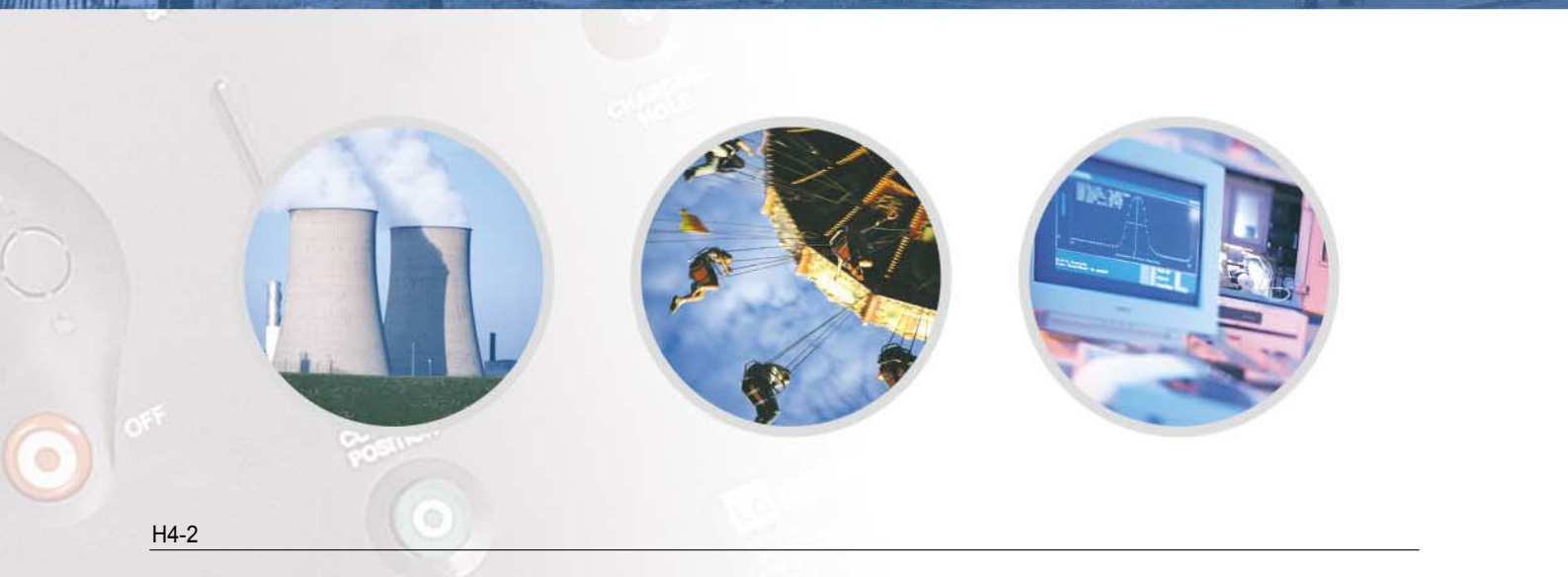

## >> Vacuum Circuit Breakers



### VCB Full Option

To prevent fatal error, property and life loss caused from operator during operation, it is equipped with safety mechanisms such as shutter padlock.

### Bushing applied for Window CT adaptation

The bushing provides sufficient strength to collaborate with the internal insulation and is adaptable with CT offering safety mechanically and electrically when applying large current.

### Satisfies earthquake and other internal environment specifications

During the lifespan of power stations (40yrs), it is designed to operate its fundamental breaking functions even under the most severe conditions like earthquake, which is critical from safety perspectives. These technologies proven through tests that comply with KEPIC standard and relevant specifications are to guarantee nuclear reactor safety.

# Vacuum Circuit Breaker for Nuclear Power Plants

## Ratings

Type		LVB-05G-50B	LVB-15G-40B
Rated voltage	(kV)	4.76	15
Rated normal current	(A)	1200	1200
		2000	2000
		3000	-
Rated frequency	(Hz)	60	60
Rated short-circuit breaking current	(kA)	50	40
Rated short-circuit breaking capacity	(MVA)	410	1040
Rated short-time withstand current	(kA/3sec)	50	40
Rated short-circuit making current	(kA)	130	104
Rated breaking time	(Cycle)	3	3
Rated opening time	(sec)	≤ 0.04	≤ 0.04
No-load closing time	(sec)	≤ 0.06	≤ 0.06
Withstand voltage	Power frequency (kV/1min)	19	36
	Impulse (kV/1.2 × 50 $\mu$ s)	60	95
Rated operating sequence		0-0.3s-CO-3min-CO	
Rated charging motor current	DC 125V (A)	5	5
Rated closing coil current	DC 125V (A)	3	3
Rated shunt coil current	DC 125V (A)	3	3
Lifetime	Mechanical(w/o maintenance)	10000 operations	10000
	Electrical(w/o maintenance)	10000 operations	10000
Auxiliary switch		5a3b	5a3b
Installing		G-type	G-type
Weight	1200,2000A (kg)	300	300
	3000A (kg)	350	-
Applied standard		ANSI C37	ANSI C37
Type test laboratory		KERI	KERI

## Motor

When the closing spring is charged, the control power of motor is turned off by the built-in limit s/w.

Rated voltage	The peak value of the inrush current (A)		Rated current(A)		Range of the normal operating voltage	Consumption power (W)	Charging time (sec)
	4.76kV	15kV	4.76kV	15kV			
	50kA	40kA	50kA	40kA			
DC 125V	15	15	5	5	90~140	360	8

## Closing Coil (C)

When the rated volt is applied to the coil the breaker is closed. The electrical anti-pumping circuit is built-in it.

Rated voltage	The peak value of the inrush current (A)		Range of the normal operating voltage
	4.76kV	15kV	
	50kA	40kA	
DC 125V	3	3	90 ~ 140

## Shunt Coil (TC)

When the rated volt is applied to the coil the breaker is opened.

Rated voltage	The peak value of the inrush current (A)		Range of the normal operating voltage
	4.76kV	15kV	
	50kA	40kA	
DC 125V	3	3	70 ~ 140

## Auxiliary switch

Standard configuration : Reversible 8C(5a3b) and 2c(2b) with early-b contact function

Classification		Resistive load(A)	Inductive load(A)	Contact configuration
Contact Ratings	AC	250V	10	8c
		125V	10	
	DC	250V	10	
		125V	10	
		30V	10	

Position of the Auxiliary switch

Breaker	Switch	Mechanism		MOC		TOC	
		a	b	a b		a b	
RUN	CLOSE	ON	OFF	ON	OFF	ON	OFF
	OPEN	OFF	ON	OFF	ON	OFF	ON
TEST	CLOSE	ON	OFF	ON	OFF	ON	OFF
	OPEN	OFF	ON	OFF	ON	OFF	ON

Note) The contact ratings of Mechanical Operated Cell Switch(MOC) are the same with that of the Aux. switch.

## Charge indicator of the closing spring

Indicating the condition of the closing spring.



## Position indicator of the main contacts

Indicating the 'Close' or the 'Open' of the main contacts.

Close position: 「ON」 Open position: 「OFF」



## Counter

Mechanically counts the operation of the VCB by 5digits

# Vacuum Circuit Breaker for Nuclear Power Plants

## Accessories

### Accessories for breakers

- **Position padlock**

It is located at the screw hole to prevent the draw-in and out of a breaker from the present position(Disconnected, Test or Connected)

- **Mechanical position indicator**

It is located in the lower part of a breaker to check the present position - Disconnected, Test or Connected- easily.

- **Auto connection**

When the breaker is moved to Test position from Disconnected position the connector for control powers is automatically connected.

In case of reverse moving of the breaker the connector is automatically disconnected.

- **Reversible contact**

10 auxiliary switches are provided. 8 of them consist of reversible 8c which can be changed from a(b) to b(a). Factory composition is 5a3b. And the other 2 switches are supplied as 2b with early-b contact function

- **Code plate**

When the breaker is inserted to the cradle, if the ratings does not match with the cradle, it mechanically prevents the breaker from being inserted into the cradle.

- **Auto discharge**

In case the breaker is drawn-out when the closing spring is charged in the position-Disconnected, Test or Connected, or the breaker is moved to Disconnected position from Test position the closing spring shall be automatically released.





## Accessories for cradles

- **Mechanically operated cell switch (MOC)**

This 6a6b switch indicates the 'ON' or 'OFF' condition of a VCB and is operated in the positions of 'Run' and 'Test'..

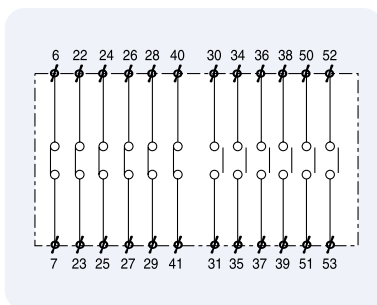

- **Truck operated cell switch (TOC)**

This 6a6b switch indicates the 'Run' state of a VCB and is operated by the movement of a VCB frame.

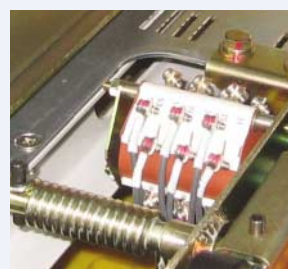
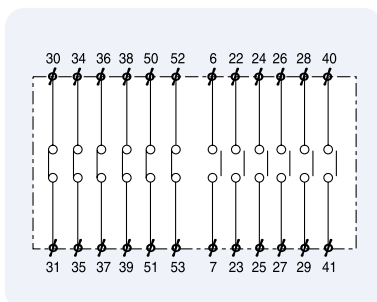

# Vacuum Circuit Breaker for Nuclear Power Plants

## Control circuit diagram

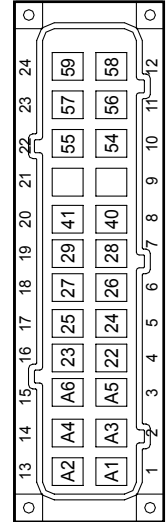
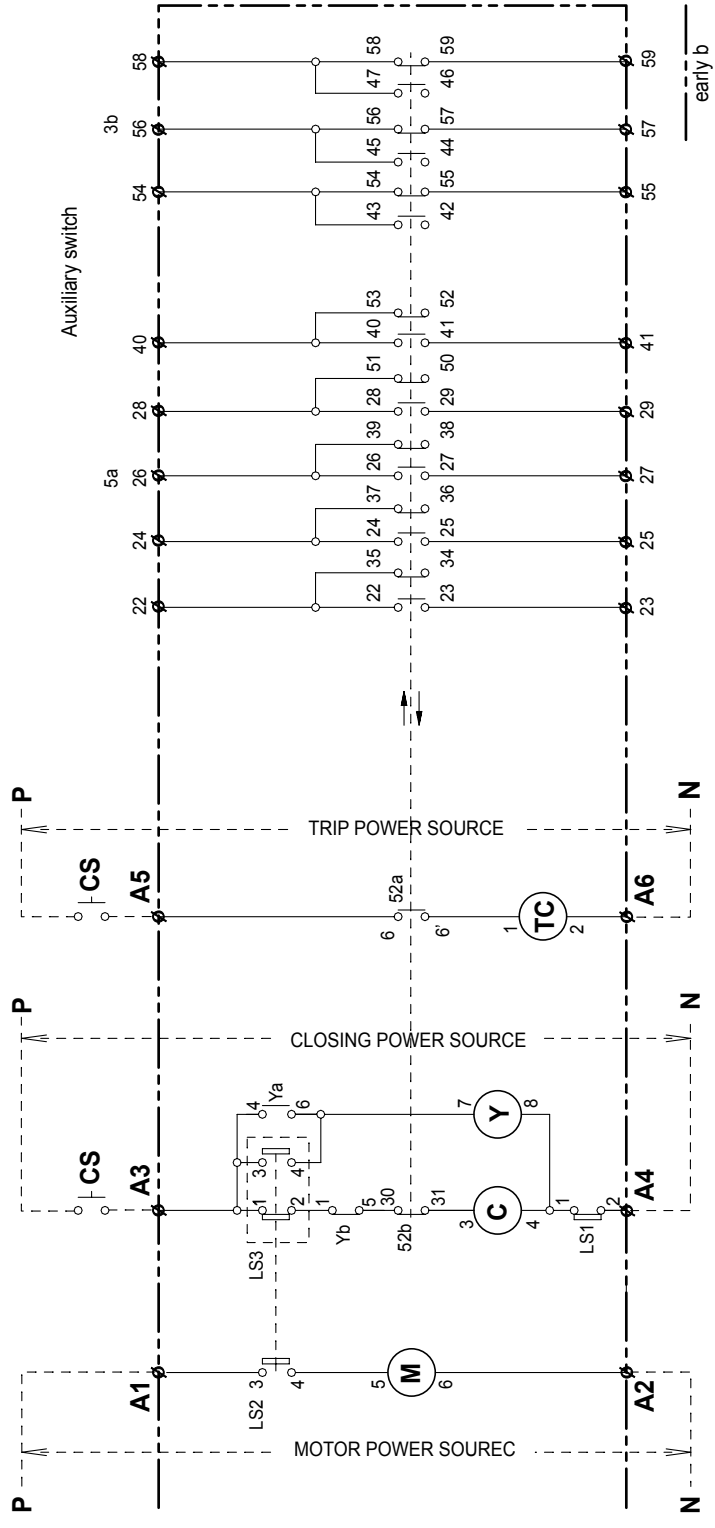

SECONDARY DISCONNECT WIRING  
(FRONT VIEW OF RECEPTACLE PLUG)

- Ø: External terminal of VCB
- 52 : Vacuum circuit breaker
- M : Spring charging motor
- TC : Trip coil
- C : Closing coil
- Y : Anti-pump relay
- 52a : Auxiliary switch (NO)
- 52b : Auxiliary switch (NC)
- LS1 : Closing interlock limit switch (only withdrawable type)
- LS2 : Motor stopping, closing spring charged indication
- LS3 : Anti-closing, Anti-pumping limit switch

Note) Diagram shows the circuit breaker in position "OFF" with closing spring "Charged"

## Breaker

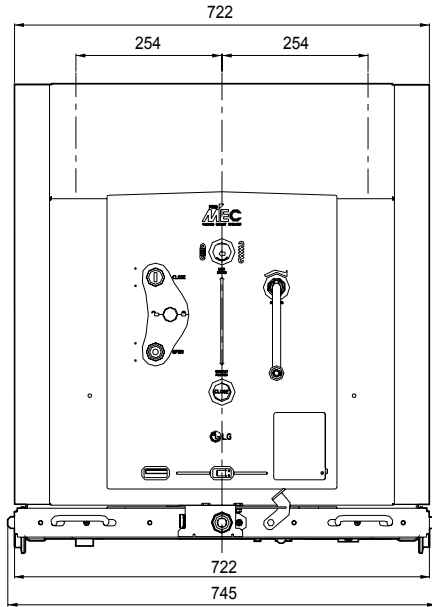

<Front view>

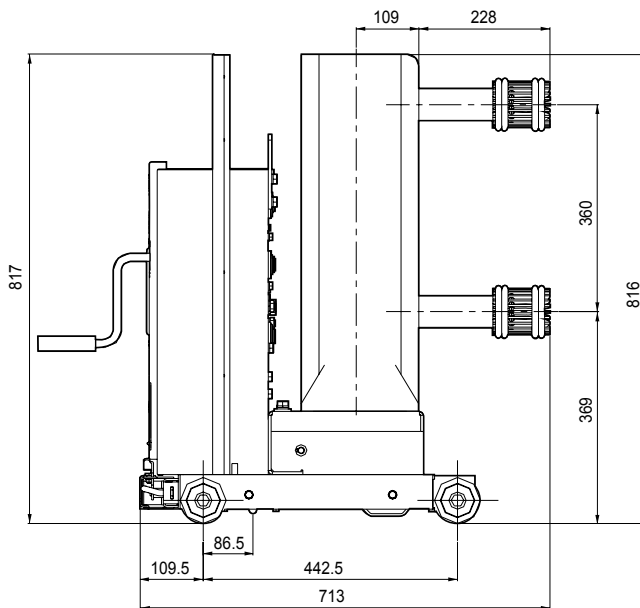
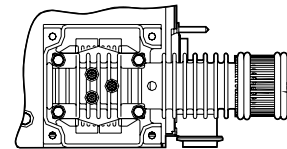
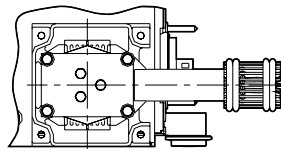

**1200/2000A**  
<Side view>

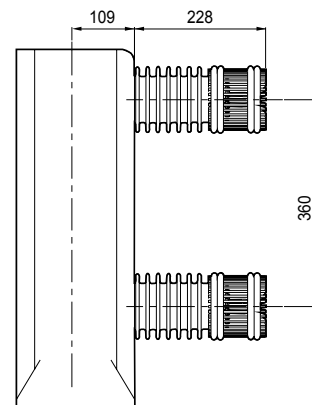

**3000A**

# Vacuum Circuit Breaker for Nuclear Power Plants

## Dimensions

### Cradle

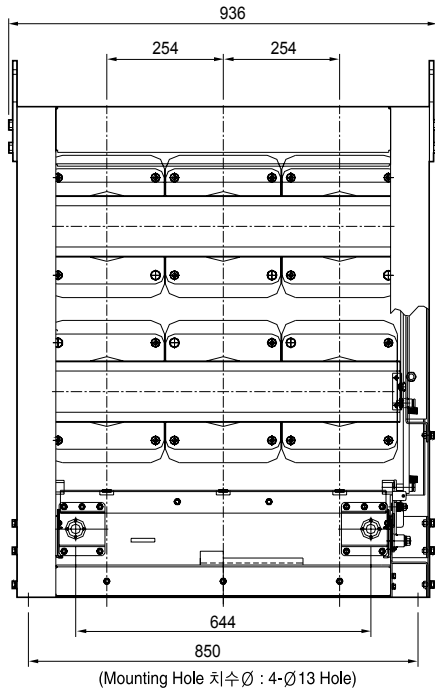

<Front view>

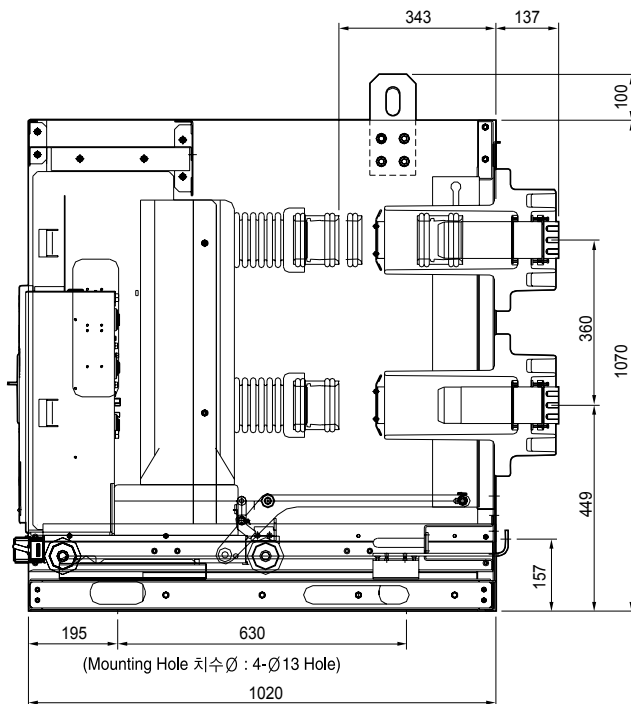

<Side view>

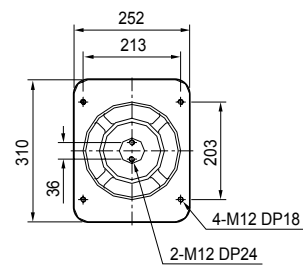

1200/2000A

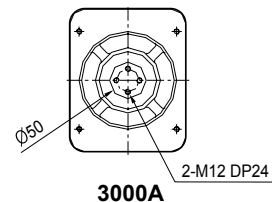

3000A

## Breaker

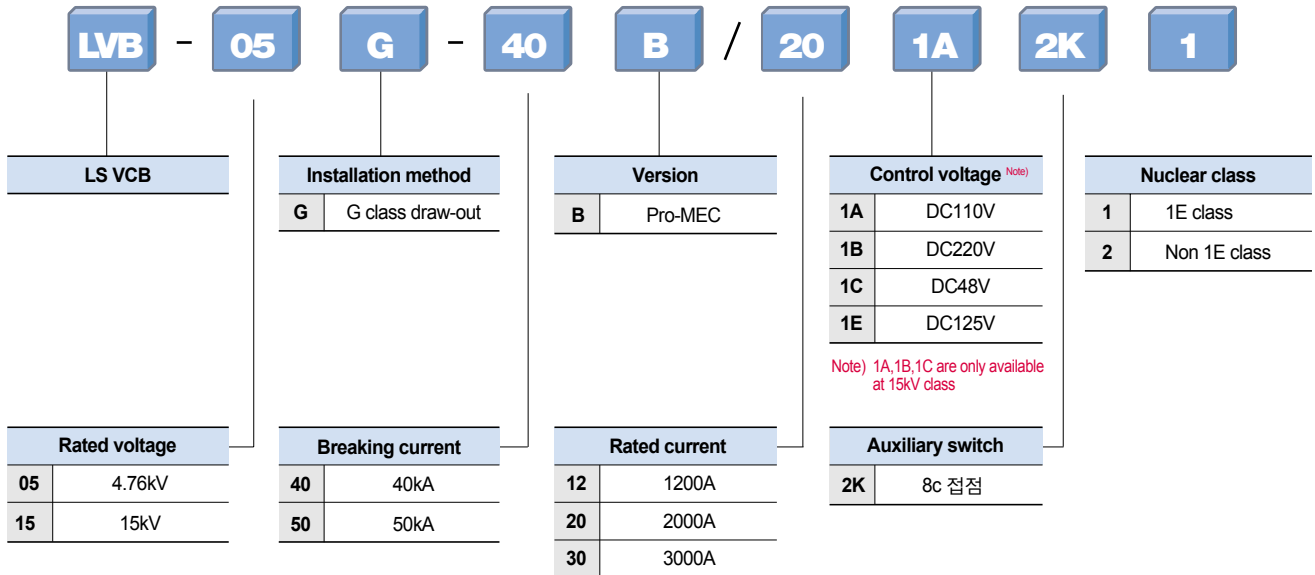

## Cradle

